

MDV 50Hz AC Fan Coil Unit 2-Pipe Cassette Series Technical Service Manual(EU)

Content

1.NOMENCLATURE	- 2 -
2.PRODUCT SCHEDULE.....	- 3 -
3.EXTERNAL APPEARANCE	- 3 -
4.FEATURES	- 4 -
5.SPECIFICATIONS.....	- 5 -
6.DIMENSION	- 8 -
7.SOUND LEVELS.....	- 9 -
8.SERVICE SPACE	- 9 -
9. MAIN PVB PORT	- 15 -
10.WIRING DIAGRAM.....	- 15 -
11.CAPACITY TABLES.....	- 22 -
12.EXPLODED VIEW	- 49 -
13.INSTALLATION	- 54 -

1. Nomenclature

1.1 Compact four-way cassette

MDV F – 300 C4C E

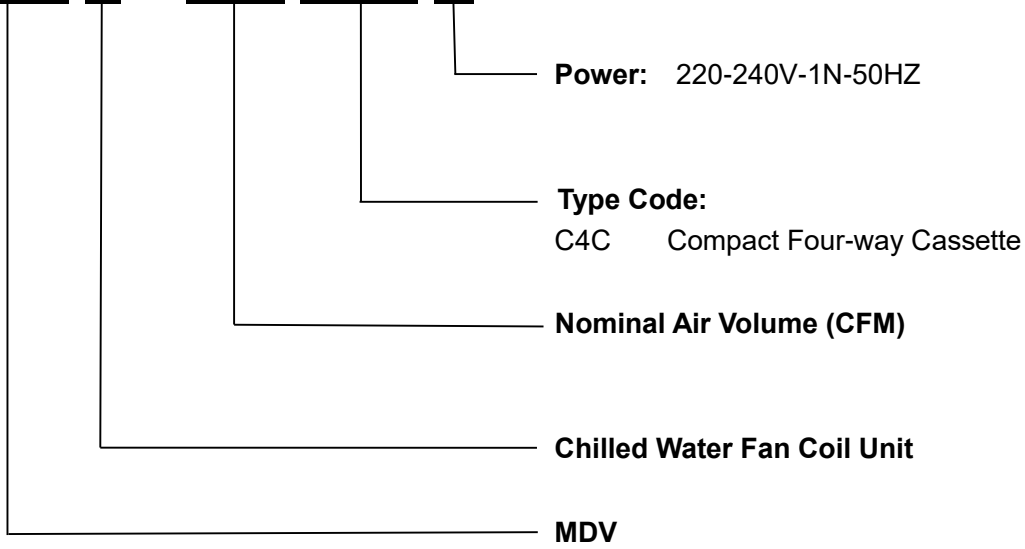

1.2 Four-way cassette

MDV F – 600 C4 E

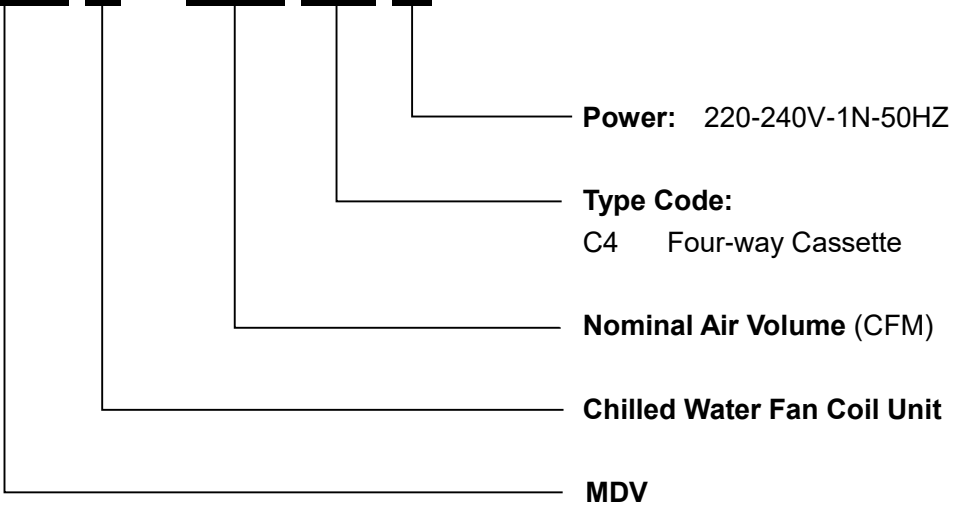

2. Product Schedule

Series	Model	Air volume (CFM)	Power supply
Four-way Cassette	MDVF-600C4E	600	220~240V-1Ph-50Hz
	MDVF-750C4E	750	
	MDVF-850C4E	850	
	MDVF-950C4E	950	
	MDVF-1200C4E	1200	
	MDVF-1500C4E	1500	
Compact Four-way Cassette	MDVF-300C4CE	300	220~240V-1Ph-50Hz
	MDVF-400C4CE	400	
	MDVF-500C4CE	500	

3. External appearance

Four-way Cassette:



Compact Four-way Cassette:



4. Features

- Wide capacity range, for four-way cassette units, from 600CFM to 1500CFM, for compact four-way units, from 300CFM to 500CFM.
- 4-way air supply panel is standard for four-way cassette; 360° air supply panel is standard for compact four-way cassette.



- Unique design of the centrifugal fan ensures extra-quiet operation and high efficiency.
- Remote controller with LED display, wired controller is optional.
- Safety grill for safety maintenance.

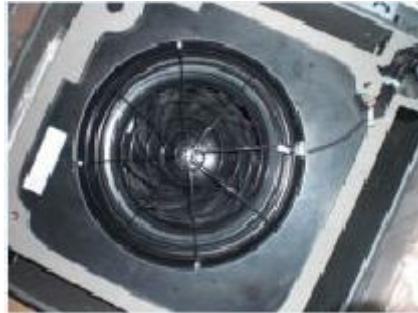

- Built in drain water pump. For four-way cassette, the pump head is 750mm; for compact four-way cassette, the pump head is 500mm.
 - Optional extended drainage pan for protecting your ceiling better.
 - Four speed motor with one reserved for more choice.
-
- In heating mode, the default return difference temperature of the standard units is 6 degrees, can be customizable to 3 degrees.

5. Specifications

Model MDVF-			600C4E	750C4E	850C4E
Power Supply		V/Ph/Hz	220-240/1/50	220-240/1/50	220-240/1/50
Air flow (H/M/L)		m ³ /h	1017/807/639	1241/977/810	1433/1100/946
		CFM	598/475/376	730/575/477	843/647/556
Cooling	Capacity (H/M/L)	kW	5.26/4.44/3.68	5.58/4.87/4.09	5.87/5.64/5.52
	Water flow rate(H/M/L)	m ³ /h	0.95/0.8/0.66	1/0.88/0.74	1.06/1.02/0.99
	Water pressure drop(H/M/L)	kPa	29.9/17.9/13	30/20.1/15	35/34.2/17.6
Heating	Capacity (H/M/L)	kW	6.07/5.16/4.38	6.67/5.9/5.03	7.64/6.45/5.84
	Water flow rate(H/M/L)	m ³ /h	1.1/0.94/0.8	1.21/1.07/0.91	1.39/1.17/1.06
	Water pressure drop(H/M/L)	kPa	28.4/21.4/19.9	37.2/23.4/18	28.3/22.8/18.9
Power input (H/M/L)		W	130/95/68	140/121/108	143/140/120
Auxiliary electric heater (AEH)		W	2100	2100	2850
Current Input		A	0.56	0.6	0.68
Sound Pressure Level (Hi/Med/Lo)		dB(A)	45/41/36	46/42/37	47/43/38
Fan Motor	Type	\	Low noise 4-speed fan motor		
	Model	\	YDK80-6E	YDK80-6E	YDK90-6E
	Brand	\	Welling	Welling	Welling/Dayang
	Capacitor	μF	3.5	3.5	3.5
	Quantity	\	1	1	1
Fan	Type	\	Centrifugal, forward-curved blades		
	Quantity	\	1	1	1
Coil	Diameter	mm	Φ7	Φ7	Φ7
	Row	\	2	2	2
	Tube Pitch(a) x Row Pitch(b)	\	21×13.37	21×13.37	21×13.37
	Fin Spacing	\	1.5	1.5	1.5
	Fin Type	\	Hydrophilic aluminum		
	Length x Height x Width	mm	1960×168×26.74	1960×168×26.74	1960×252×26.74
	Max. Working Pressure	MPa	1.6	1.6	1.6
	Circuit	\	8	8	12
Panel	Net Dimension (W×H×D)	mm	950×45×950	950×45×950	950×45×950
	Net Weight	kg	6	6	6
	Packing Size (W×H×D)	mm	1035×90×1035	1035×90×1035	1035×90×1035
	Gross Weight	kg	9	9	9
Indoor Unit	Net Dimension (W×H×D)	mm	840×230×840	840×230×840	840×300×840
	Net Weight (without/with EAH)	kg	25/27	25/27	30.5/33
	Packing Size (W×H×D)	mm	900×260×900	900×260×900	900×330×900
	Gross Weight (without/with EAH)	kg	30/32	30/32	36.2/39
Pipe Connection	Water-inlet Pipe	inch	RC3/4	RC3/4	RC3/4
	Water-outlet Pipe	inch	RC3/4	RC3/4	RC3/4
	Drain Pipe	mm	ODΦ32	ODΦ32	ODΦ32

Specifications

Model MDVF-			950C4E	1200C4E	1500C4E
Power Supply		V/Ph/Hz	220-240/1/50	220-240/1/50	220-240/1/50
Air flow (H/M/L)		m ³ /h	1562/1183/1013	1606/1276/1059	1690/1324/1091
		CFM	919/696/596	945/751/623	994/779/642
Cooling	Capacity (H/M/L)	kW	6.09/6.21/5.78	7.07/6.38/6.02	9.68/6.77/7.05
	Water flow rate(H/M/L)	m ³ /h	1.1/1.12/1.04	1.27/1.15/1.08	1.74/1.22/1.27
	Water pressure drop(H/M/L)	kPa	27.1/22/18.1	45/45/45	40/27.2/25
Heating	Capacity (H/M/L)	kW	7.92/7.35/6.63	8.02/7.55/6.76	10.96/8.9/7.84
	Water flow rate(H/M/L)	m ³ /h	1.44/1.34/1.21	1.46/1.37/1.23	1.99/1.62/1.42
	Water pressure drop(H/M/L)	kPa	31.7/26.2/22.1	45/45/45	50/35/25
Power input (H/M/L)		W	190/160/130	183/159/146	219/150/123
Auxiliary electric heater (AEH)		W	2850	2850	/
Current Input		A	0.7	0.86	0.86
Sound Pressure Level (Hi/Med/Lo)		dB(A)	48/44/39	49/45/40	50/46/41
Fan Motor	Type	\	Low noise 4-speed fan motor		
	Model	\	YDK90-6E	YDK90-6E	YDK90-6E-1
	Brand	\	Welling/Dayang	Welling/Dayang	Welling/Dayang
	Capacitor	μF	3.5	3.5	3.5
	Quantity	\	1	1	1
Fan	Type	\	Centrifugal, forward-curved blades		
	Quantity	\	1	1	1
Coil	Diameter	mm	Φ7	Φ7	Φ7
	Row	\	2	2	3
	Tube Pitch(a) x Row Pitch(b)	\	21×13.37	21×13.37	21×13.37
	Fin Spacing	\	1.5	1.5	1.5
	Fin Type	\	Hydrophilic aluminum		
	Length x Height x Width	mm	1960×252×26.74	1960×252×26.74	2080×252×40.11
	Max. Working Pressure	MPa	1.6	1.6	1.6
Circuit	\	12	12	12	
Panel	Net Dimension (W×H×D)	mm	950×45×950	950×45×950	950×45×950
	Net Weight	kg	6	6	6
	Packing Size (W×H×D)	mm	1035×90×1035	1035×90×1035	1035×90×1035
	Gross Weight	kg	9	9	9
Indoor Unit	Net Dimension (W×H×D)	mm	840×300×840	840×300×840	840×300×840
	Net Weight (without/with EAH)	kg	30.5/33	30.5/33	31.8
	Packing Size (W×H×D)	mm	900×330×900	900×330×900	900×330×900
	Gross Weight (without/with EAH)	kg	36.2/39	36.2/39	36
Pipe Connection	Water-inlet Pipe	inch	RC3/4	RC3/4	RC3/4
	Water-outlet Pipe	inch	RC3/4	RC3/4	RC3/4
	Drain Pipe	mm	ODΦ32	ODΦ32	ODΦ32

Specifications

Model MDVF-			300C4CE	400C4CE	500C4CE
Power supply		V/Ph/Hz	220-240/1/50		
Air flow (H/M/L)		m ³ /h	478/375/283	625/499/392	756/535/423
		CFM	281/221/167	368/294/231	445/315/249
Cooling	Capacity (H/M/L)	kW	2.5/2.02/1.61	3.09/2.52/2.08	4.06/3.2/2.52
	Water flow rate(H/M/L)	L/h	0.45/0.36/0.29	0.56/0.45/0.37	0.73/0.58/0.45
	Water pressure drop(H/M/L)	kPa	15/15/10	15/15/10	20/15/10
Heating	Capacity (H/M/L)	kW	2.92/2.41/1.9	3.59/2.98/2.51	4.57/3.48/2.73
	Water flow rate(H/M/L)		0.53/0.44/0.34	0.65/0.54/0.46	0.83/0.63/0.5
	Water pressure drop(H/M/L)	kPa	15.4/15/10	20/15/10	20/15/15
Power input (H/M/L)		W	50/40/32	70/52/40	92/56/41
Sound pressure level (H/M/L)		dB(A)	36/33/28	42/39/32	45/42/34
Current Input		A	0.22	0.3	0.4
Fan Motor	Type	\	Low noise 4-speed fan motor		
	Model	\	YDK15-6P	YDK37-4P	YDK37-4P
	Brand	\	Welling	Welling	Welling
	Capacitor	μF	1.5	2	2.5
	Quantity	\	1	1	1
Fan	Type	\	Centrifugal, forward-curved blades		
	Quantity	\	1	1	1
Coil	Diameter	mm	Φ7	Φ7	Φ7
	Row	\	2	2	2
	Tube Pitch(a) x Row Pitch(b)	\	21×13.37	21×13.37	21×13.37
	Fin Spacing	\	1.3	1.3	1.3
	Fin Type	\	Hydrophilic aluminum		
	Length x Height x Width	mm	1315×210×26.74	1315×210×26.74	1315×210×26.74
	Max. Working Pressure	MPa	1.6	1.6	1.6
Circuit	\	5	6	7	
Panel	Net Dimension (W×H×D)	mm	647×50×647	647×50×647	647×50×647
	Net Weight	kg	3	3	3
	Packing Size (W×H×D)	mm	715×123×715	715×123×715	715×123×715
	Gross Weight	kg	5	5	5
Indoor Unit	Net Dimension (W×H×D)	mm	575×261×575	575×261×575	575×261×575
	Net Weight	kg	16.5	16.5	16.5
	Packing Size (W×H×D)	mm	670×290×670	670×290×670	670×290×670
	Gross Weight	kg	20	20	20
Pipe Connection	Water-inlet Pipe	inch	G3/4	G3/4	G3/4
	Water-outlet Pipe	inch	G3/4	G3/4	G3/4
	Drain Pipe	mm	ODΦ25	ODΦ25	ODΦ25

Note: 1. The data is the performance in high speed with relevant static pressure.

2. Cooling Conditions: Entering Water 7°C, Temperature Rise 5°C, Entering Air Temperature 27°C DB, 19°C WB.

Heating conditions: Entering water 45°C, leaving water 40°C, Entering air temperature 20°C DB..

3. Noise is tested in a semi-anechoic test room

6. Dimension

Four-way Cassette:

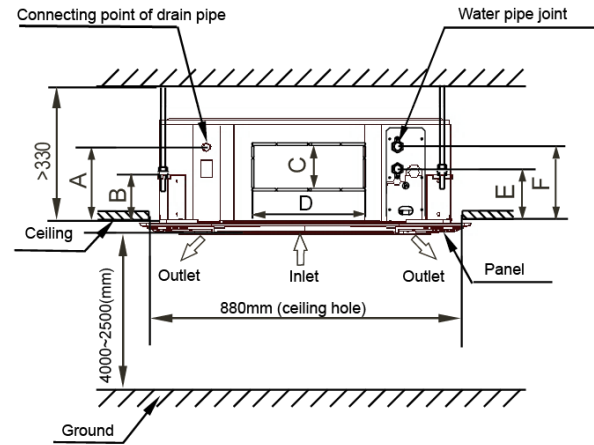
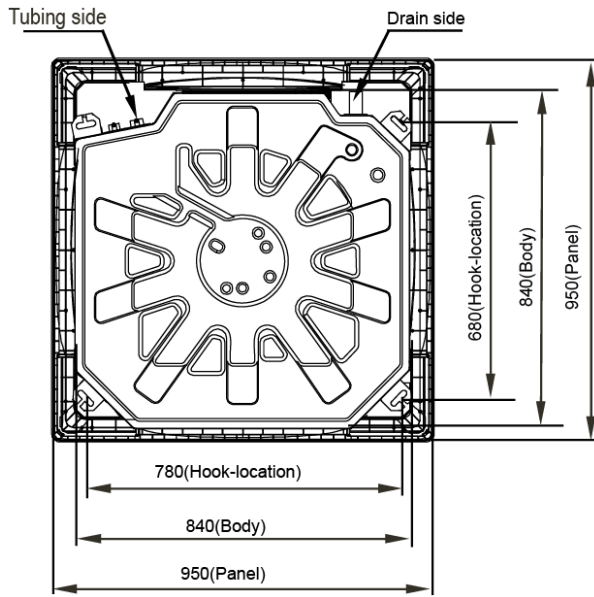

Model	A	B	C	D	E	F
600CFM, 750CFM	180	140	85	350	145	195
850CFM, 950CFM, 1200CFM, 1500CFM	180	140	155	350	155	205

Compact Four-way cassette:

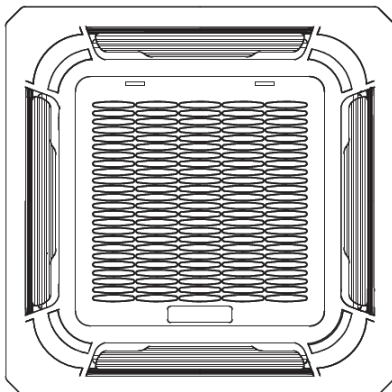
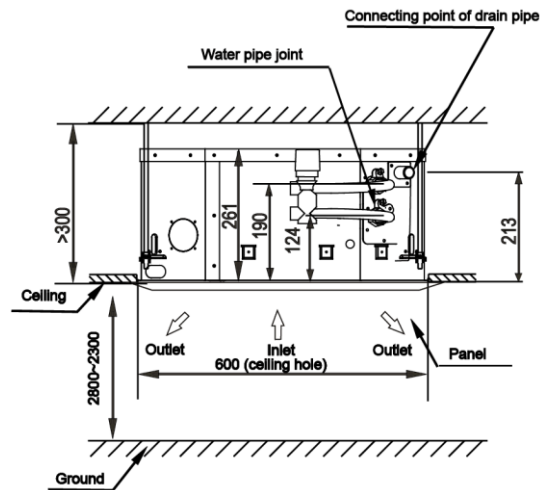
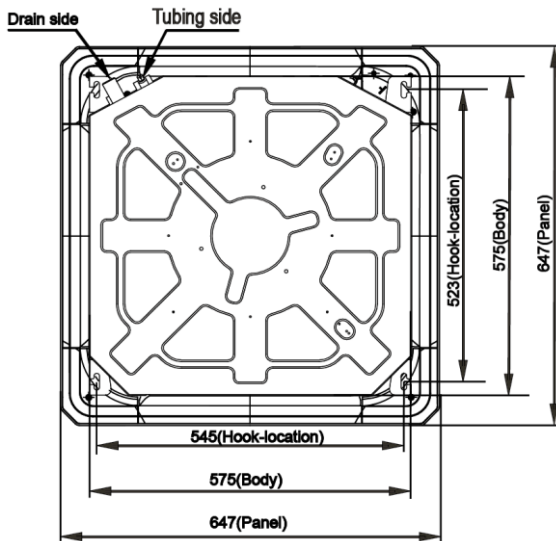

H=45mm (Four-way cassette)
 H=50mm (Compact four-way cassette)

7. Sound Levels

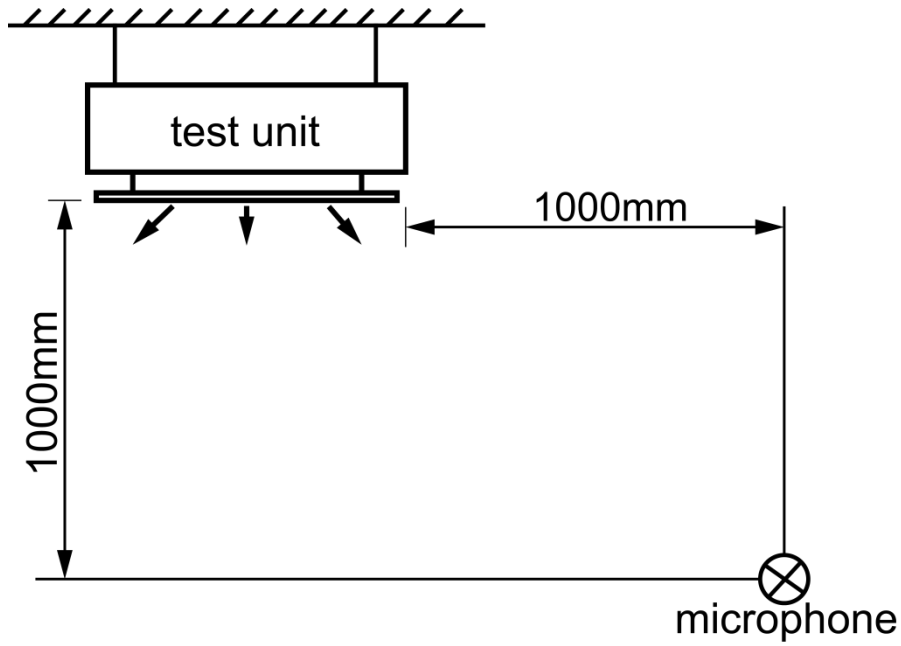

Series	Model	Sound pressure level under three fan speed [dB(A)]		
		H	M	L
Four-way Cassette	MDVF-600C4E	45	41	36
	MDVF-750C4E	46	42	37
	MDVF-850C4E	47	43	28
	MDVF-950C4E	48	44	39
	MDVF-1200C4E	49	45	40
	MDVF-1500C4E	50	46	41
Compact Four-way Cassette	MDVF-300C4CE	36	33	28
	MDVF-400C4CE	42	39	32
	MDVF-500C4CE	45	42	34

MDVF-600C4E

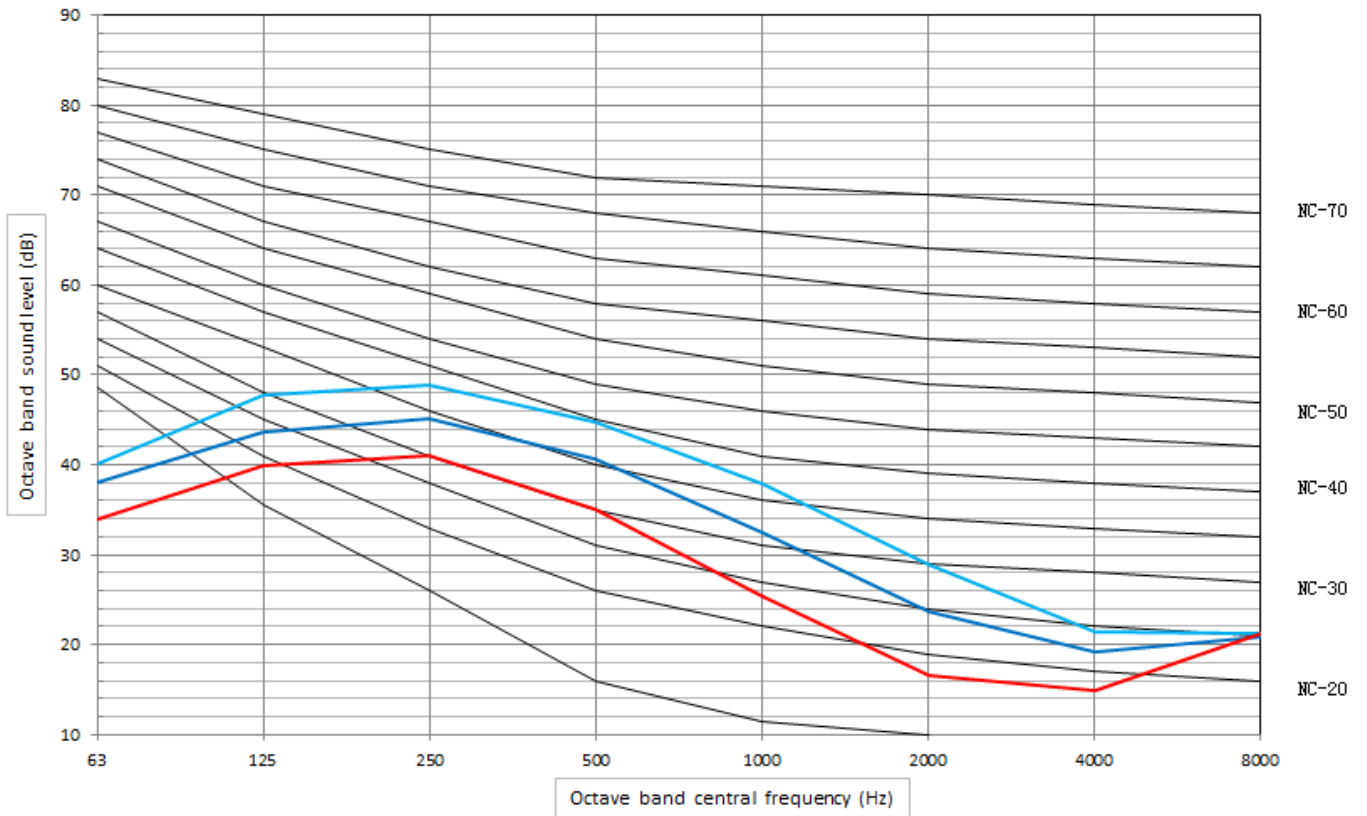

MDVF-750C4E

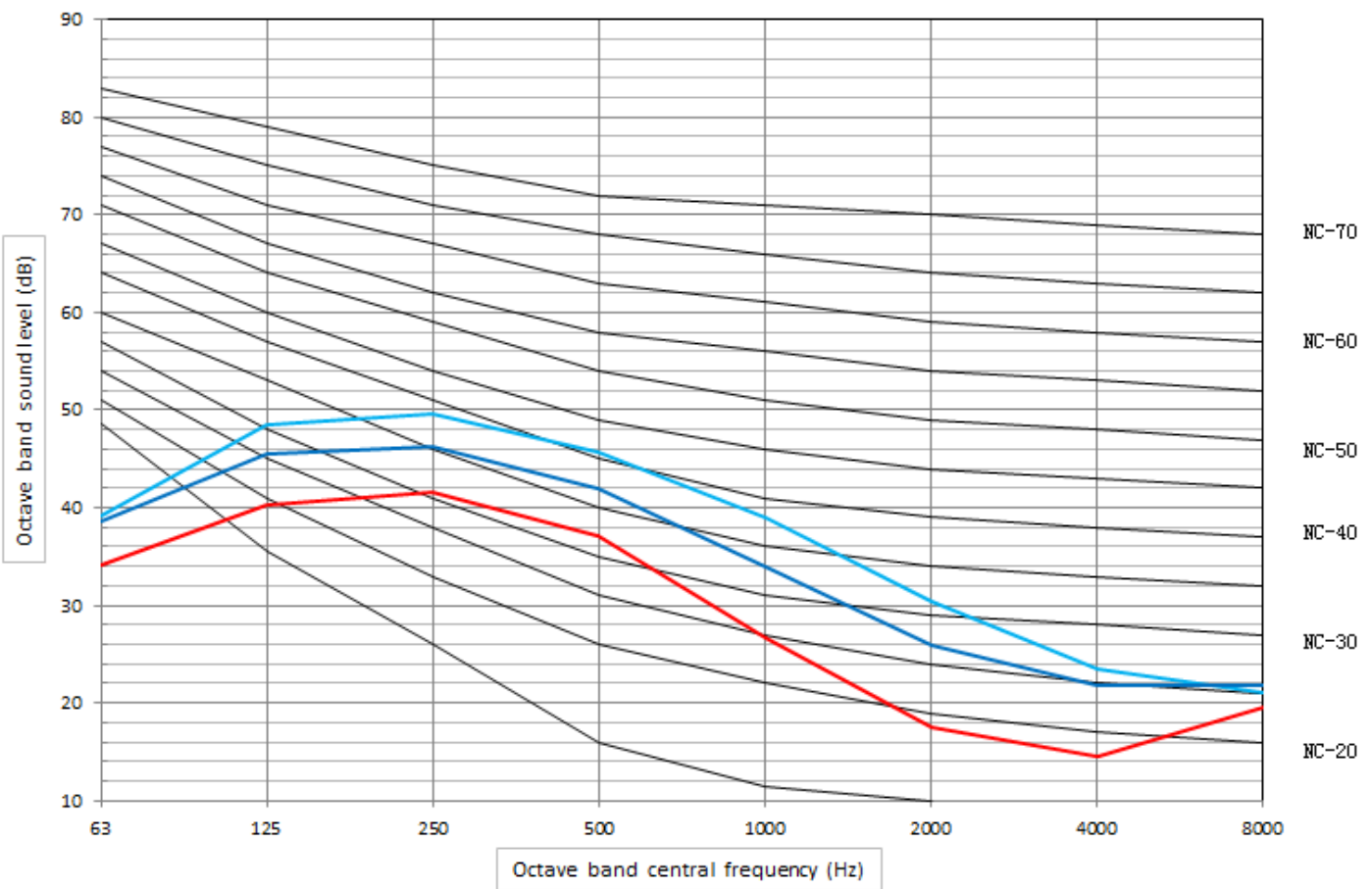

MDVF-850C4E

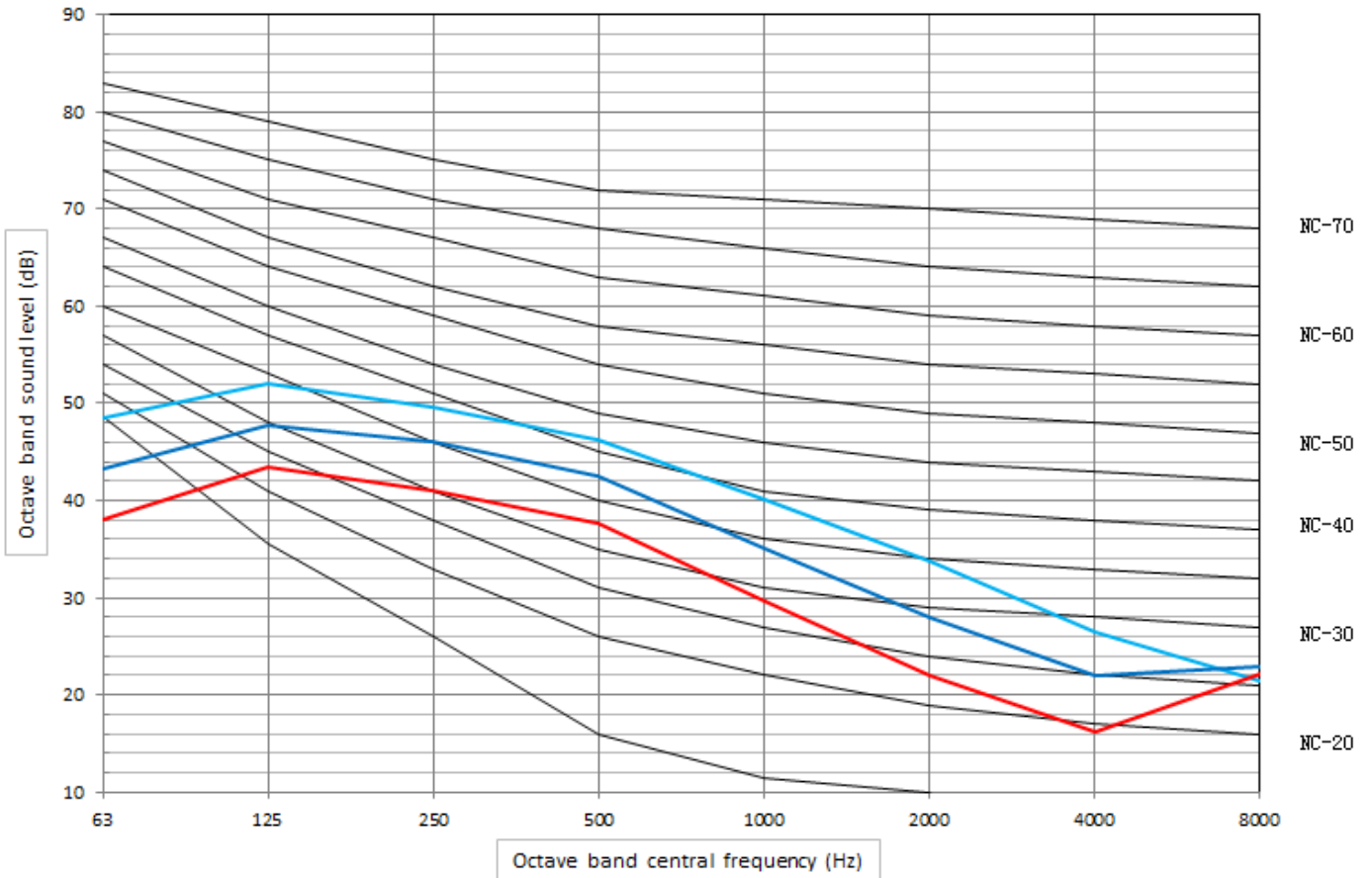

MDVF-950C4E

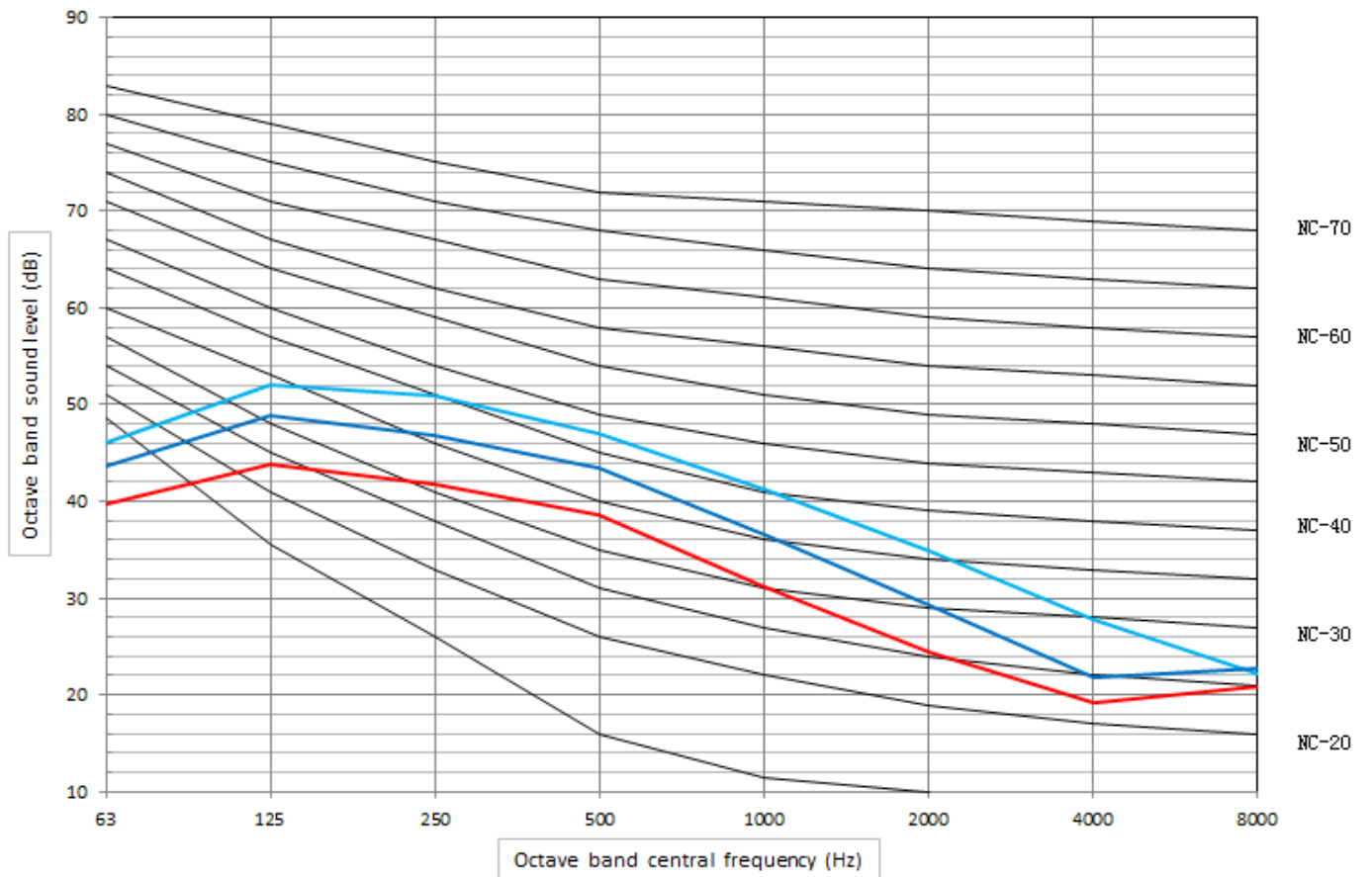

MDVF-1200C4E

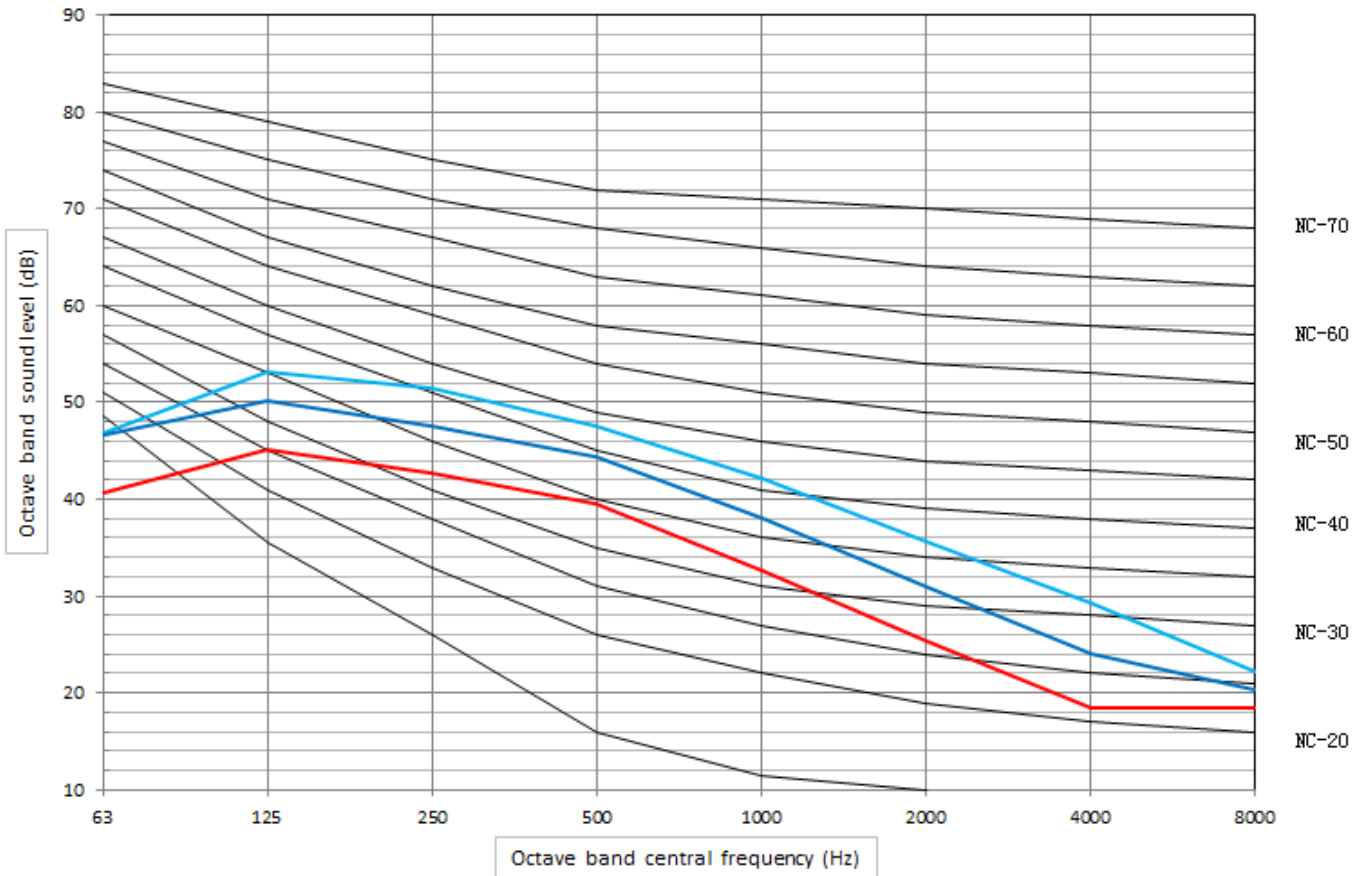

MDVF-1500C4E

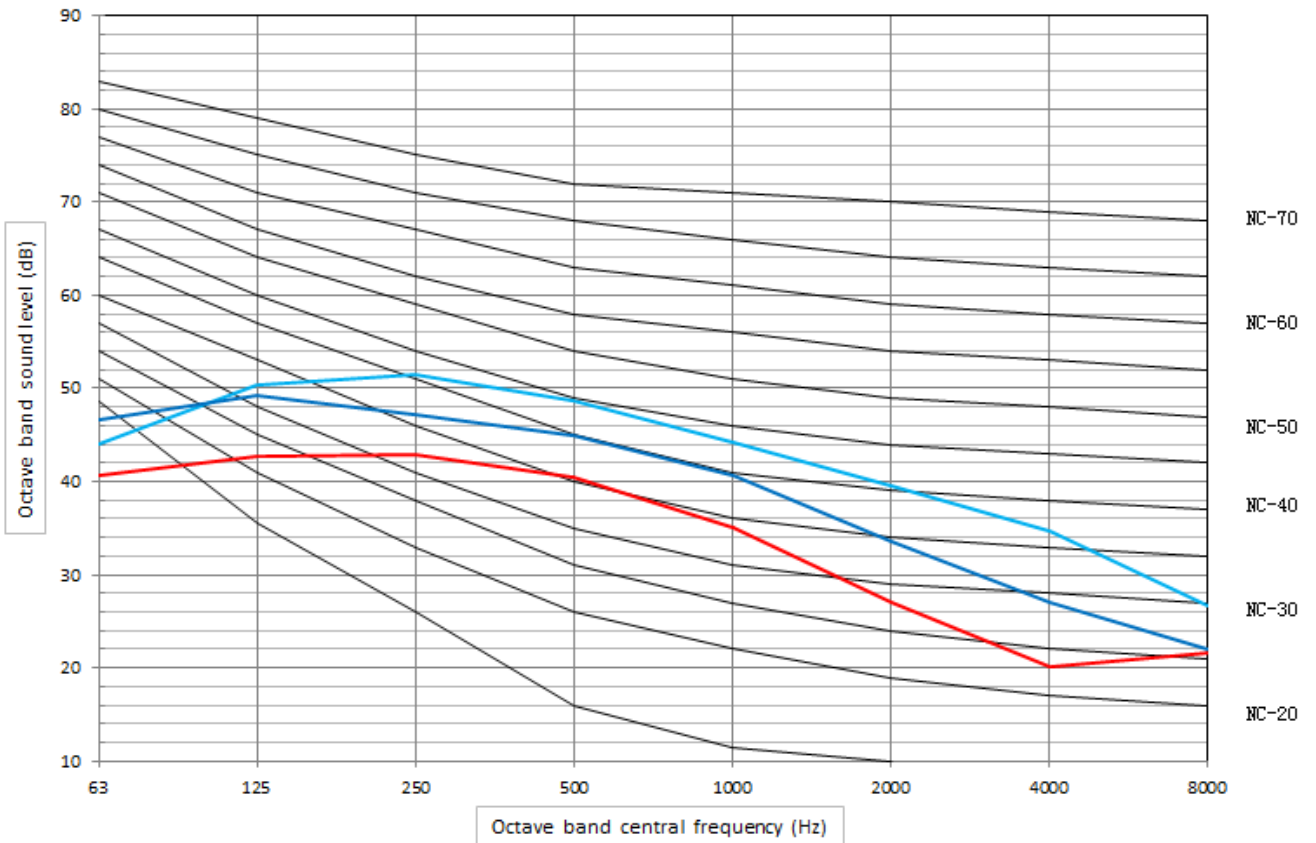

MDVF-300C4CE

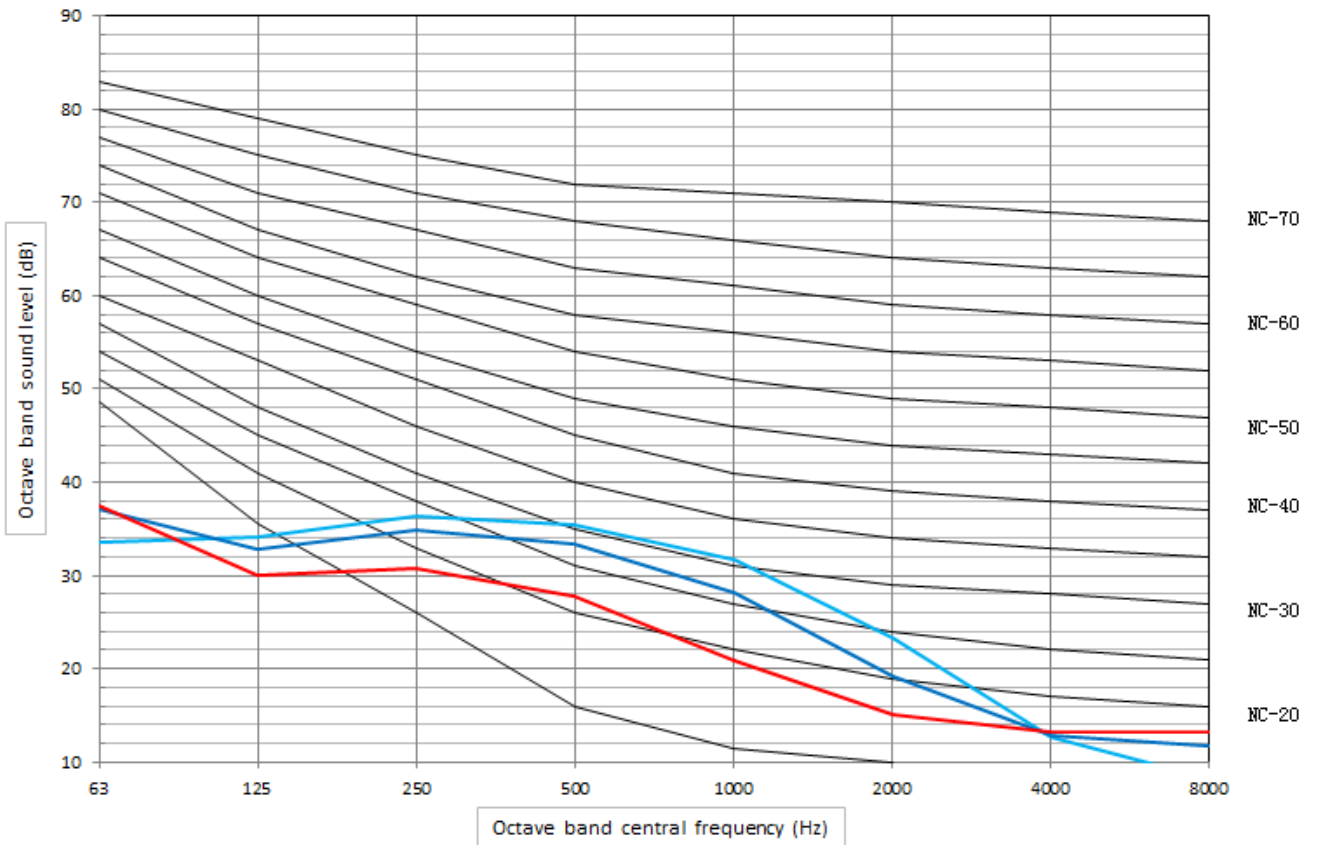

MDVF-400C4CE

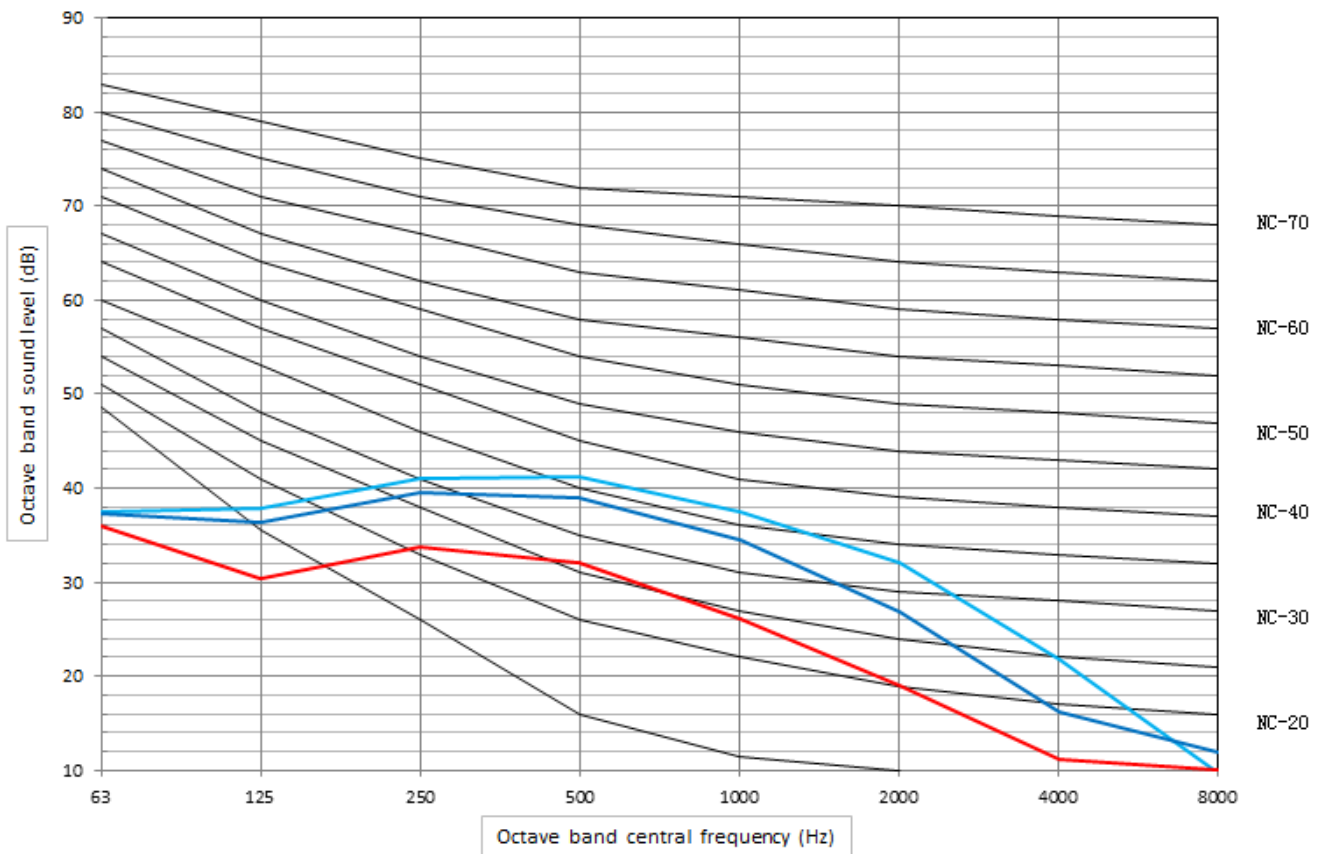

MDVF-500C4CE

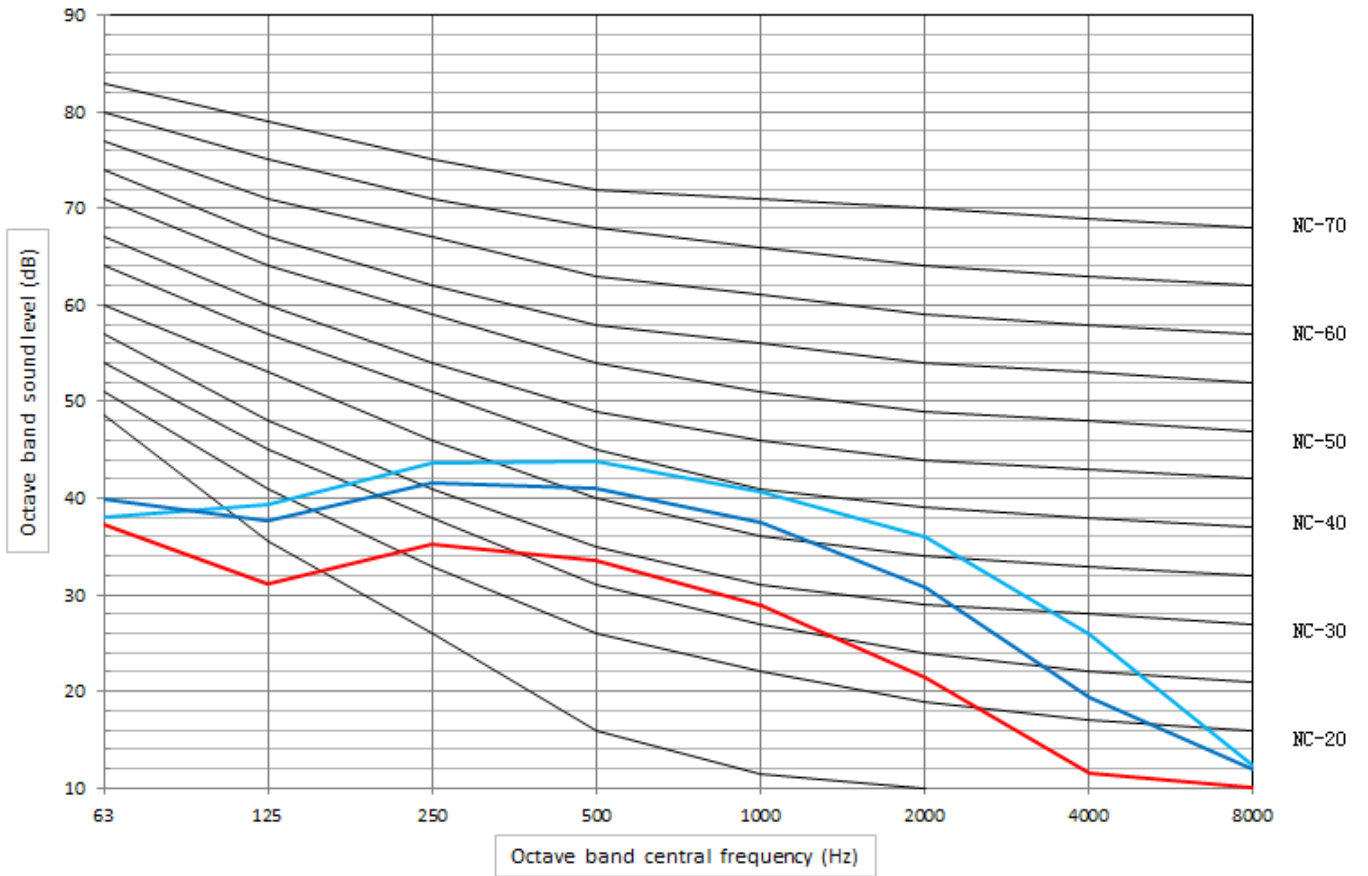

8. Service Space

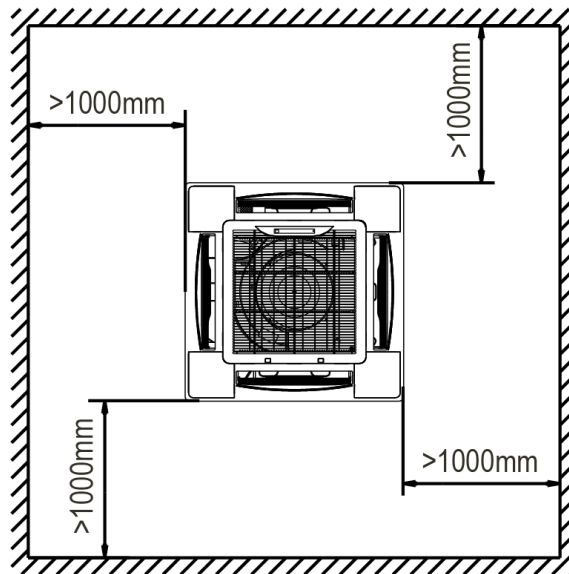

9. Mmain PCB ports

Four-way Cassette: MDVF-600C4E, MDVF-750C4E, MDVF-850C4E, MDVF-950C4E, MDVF-1200C4E, MDVF-1500C4E

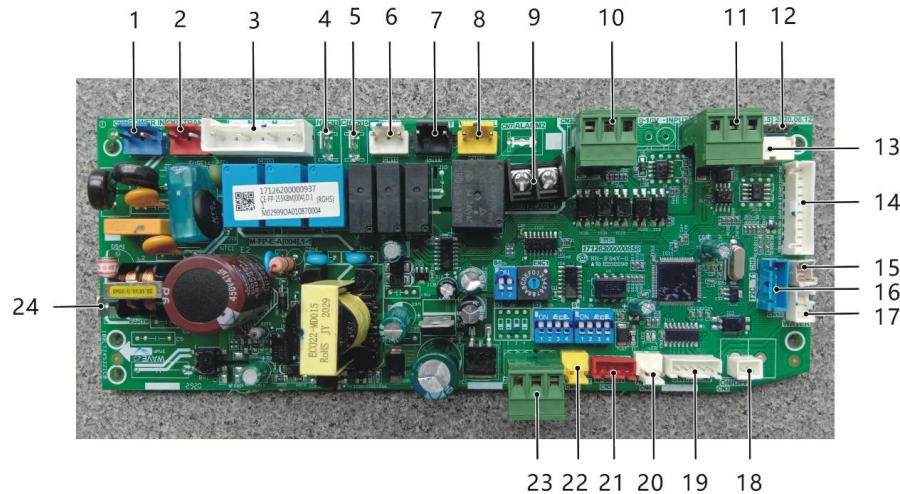

Main PCB port description:

No.	Bit No.	Description	Remarks
1	CN21	POWER: Mains input	Standard
2	CN28	TRANS IN: 0-10V body powered linear transformer primary	Customized
3	CN16	L: Low fan speed output port for AC fan	Standard
		M: Medium fan speed output port for AC fan	
		H: High fan speed output port for AC fan	
		N: Null line output port for AC fan	
4	CN1	H: High fan speed output port for AC fan	Standard
5	CN15	HH: Super-high wind profile reserved port for AC fan (suspended)	Standard
6	CN19	PUMP: Water pump output port	Standard
7	CN11	VALVE-H: Heating 2-way/3-way valve (live line/null line)	Standard (four pipe only)
8	CN12	VALVE-C: Cooling 2-way/3-way valve (live line/null line)	Standard
9	CN13	ALARM: Fault alarm output	Standard
10	CN23	XYE: Centralized control communication port	Standard
11	CN22	PQE: Modbus communication port	Customized
12	CN20	E - side program burning port	Standard
13	CN300	DEBUG: Main control program burn port	Standard
14	CN10	NEW DISPLAY: Display panel docking port (ten cores)	Standard
15	CN8	T2H: Heating pipe temperature sensor port	Standard (four pipe only)
16	CN5	T2C: Refrigerating pipe temperature sensor port	Standard
		T1: Room temperature sensor port	
17	CN18	WATER: Water level switch port	Standard
18	CN3	ON/OFF: Remote on/off port	Customized
19	CN2	SWING: Swing motor port	Standard
20	CN4	HEAT: Control port for auxiliary electric heating relay	Customized
21	CN30	M-Smart: 360° annular air outlet panel docking port (four cores)	Standard
22	CN14	TRANS OUT: 0-10V valve powered linear transformer secondary	Customized
23	CN25	0-10V valve control signal output	Customized
24	EARTH	EARTH: Grounding screw position	Standard

Compact Four-way Cassette: MDVF-300C4CE, MDVF-400C4CE, MDVF-500C4CE

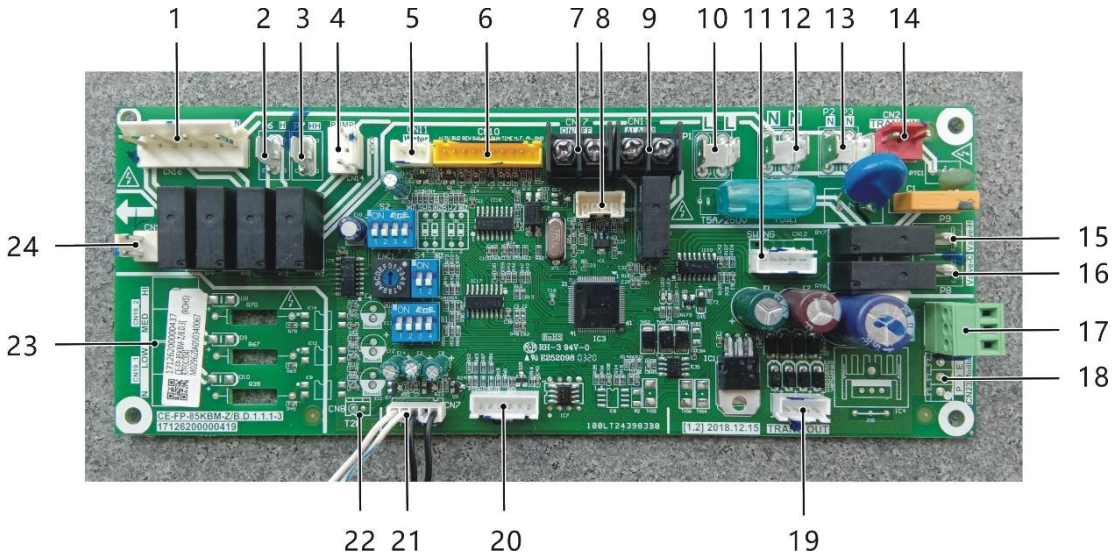

Main PCB description:

No.	Bit No.	Description	Remarks
1	CN16	L: Low fan speed output port for AC fan	Standard
		M: Medium fan speed output port for AC fan	
		H: High fan speed output port for AC fan	
		N: Null line output port for AC fan	
2	P6	H: High fan speed output port for AC fan	Standard
3	P7	HH: Super-high wind profile reserved port for AC fan (suspended)	Standard
4	CN14	PUMP: Water pump output port	Standard
5	CN11	WATER: Water level switch port	Standard
6	CN10	:Display panel docking port (ten cores)	Standard
7	CN17	ON/OFF: Remote on/off port	Standard
8	CN25	Main control program burn port	Standard
9	CN13	ALARM: Fault alarm output	Standard
10	P1	L: Power live line input	Standard
11	CN12	SWING: Swing motor port	Standard
12	P4	N: Power null line input	Standard
	P5	N: Power null line input	Standard
13	P2	N: Cooling and heating 2-way/3-way valve null line	Standard
	P3	N: Cooling and heating 2-way/3-way valve null line	Standard
14	CN2	TRANS IN: Linear transformer primary	Standard
15	P9	Valve-H: Heating 2-way/3-way valve live line	Standard (four pipe only)
16	P8	Valve-C: Cooling 2-way/3-way valve live line	Standard
17	CN18	XYE: Centralized control communication port	Standard
18	CN23	PQE: Modbus communication port	Customized
19	CN3	TRANS OUT: Linear transformer secondary	Standard
20	CN22	E - side program burning port	Standard
21	CN7	T2C: Refrigerating pipe temperature sensor port	Standard
		T1: Room temperature sensor port	Standard
22	CN8	T2H: Heating pipe temperature sensor port	Standard (four pipe only)
23	CN19_1	N: Mechanical three-speed wire controller with null line	Customized

		LOW: Mechanical three-speed wire controller with low speed	Customized
	CN19_2	MED: Mechanical three-speed wire controller with medium speed	Customized
		HI: Mechanical three-gear wire controller with high speed	Customized
24	CN9	HEAT: Control port for auxiliary electric heating relay	Customized





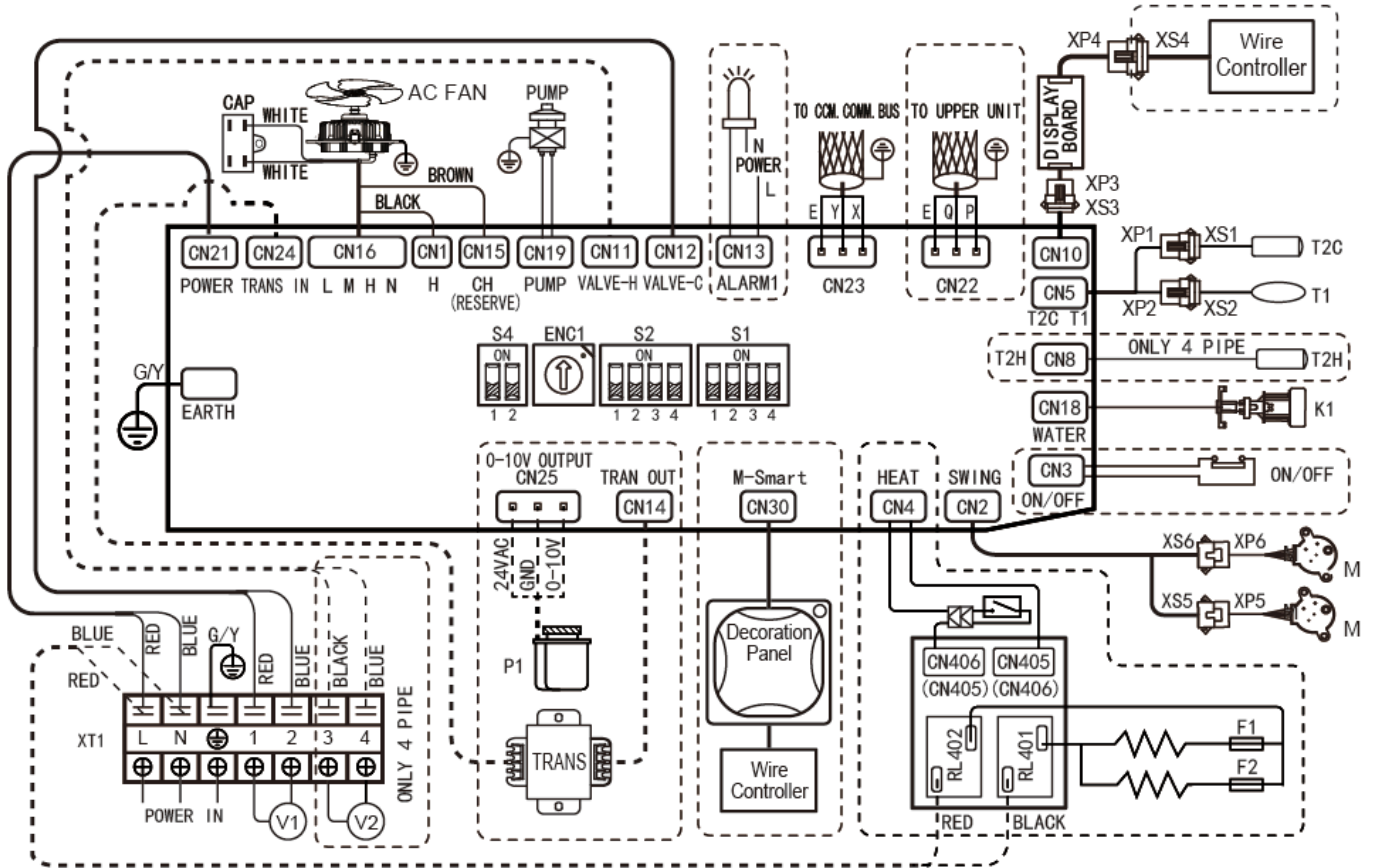



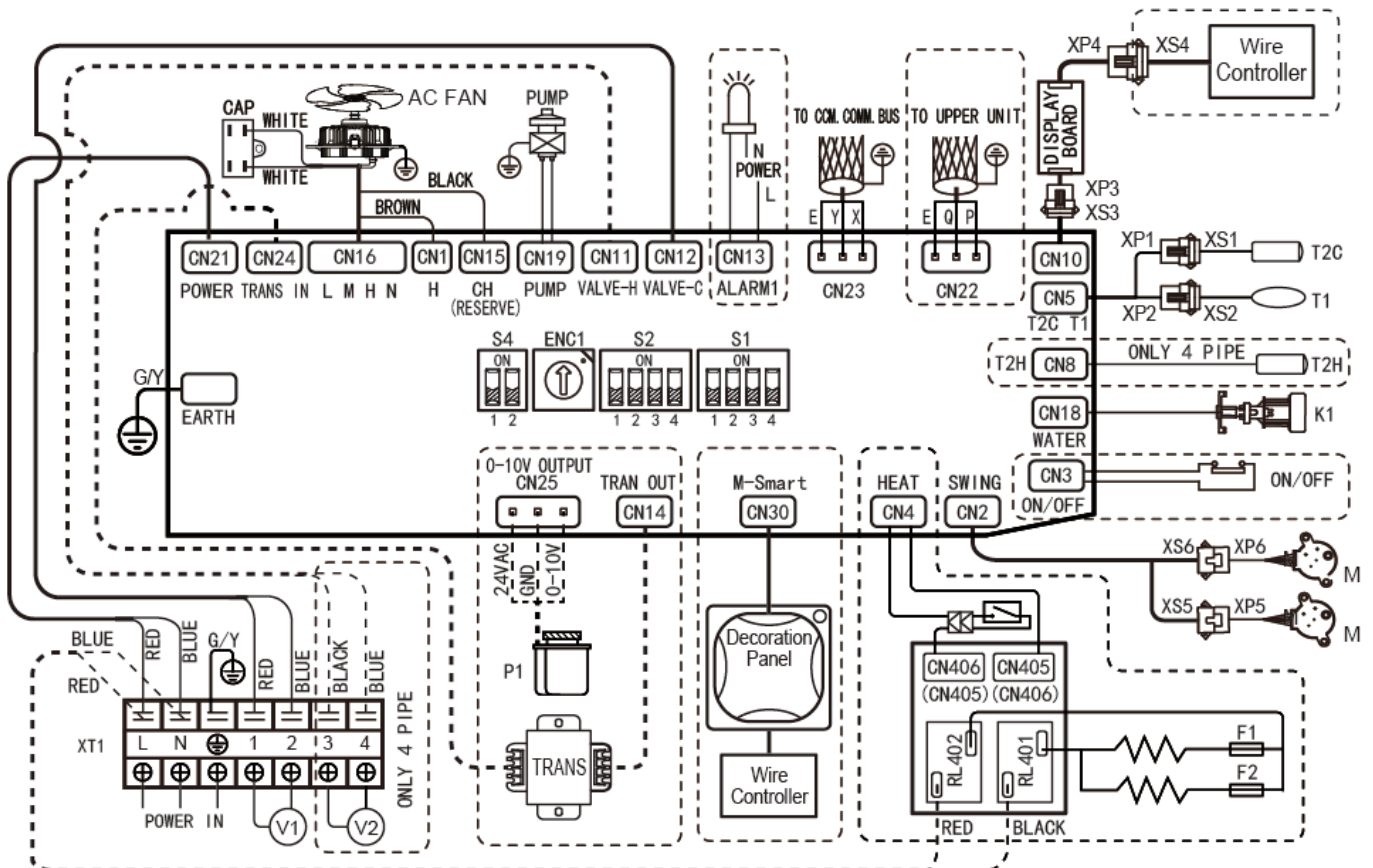



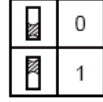



10. Wiring Diagram

Four-way Cassette: MDVF-600C4E, MDVF-750C4E, MDVF-850C4E, MDVF-950C4E, MDVF-1200C4E



MDVF-1500C4E



S1	S1-1		2 Pipe(default)	S2	S2-1/2		Temp.compensation value is 0 under cool mode(default)	 Power supply is grounded Control board is grounded			
			4 Pipe				Temp.compensation value is 1 under cool mode				
	S1-2		Without enforcement to turn wind(default)			Temp.compensation value is 2 under cool mode					
			With enforcement to turn wind			Temp.compensation value is 3 under cool mode					
	S1-3		Normal anti-cold wind(default)		S2-3/4		Temp.compensation value is 3 under heat mode(default)				
			High temperature anti-cold wind				Temp.compensation value is 1 under heat mode				
	S1-4		turn on E-heater and Heating(default)			Temp.compensation value is 6 under heat mode					
			turn on E-heater, turn off heating valve			Temp.compensation value is 8 under heat mode					
			SWITCH FOR ADDRESS SETTING		ENC1 & S4		'0-F' of the ENC1 and 'ON/OFF' of the S4, the different position represents a different address. Is be combined 64 address(0-63)		Address 0-15 Address 16-31 Address 32-47 Address 48-63		

Notes:

1. ALARM: Error codes or protections occurred, a closed signal output.
2. ON/ OFF: Short circuit, forced off; otherwise, all the controllers available.

CODE	PART NAME
CN1-30	P.C BOARD SOCKETS
K1	WATER LEVEL SWITCH
FAN	INDOOR FAN
M	SWING MOTOR
PUMP	PUMP
CAP	INDOOR FAN CAPACITOR
T1	ROOM TEMPERATURE
T2C/ T2H	PIPE TEMPERATURE
XP1-6	CONNECTORS
XS1-6	CONNECTORS
XT1	7-WAY TERMINAL
P1	PROPORTIONAL VALVE ACTUATOR

Compact Four-way Cassette: MDVF-300C4CE, MDVF-400C4CE, MDVF-500C4CE

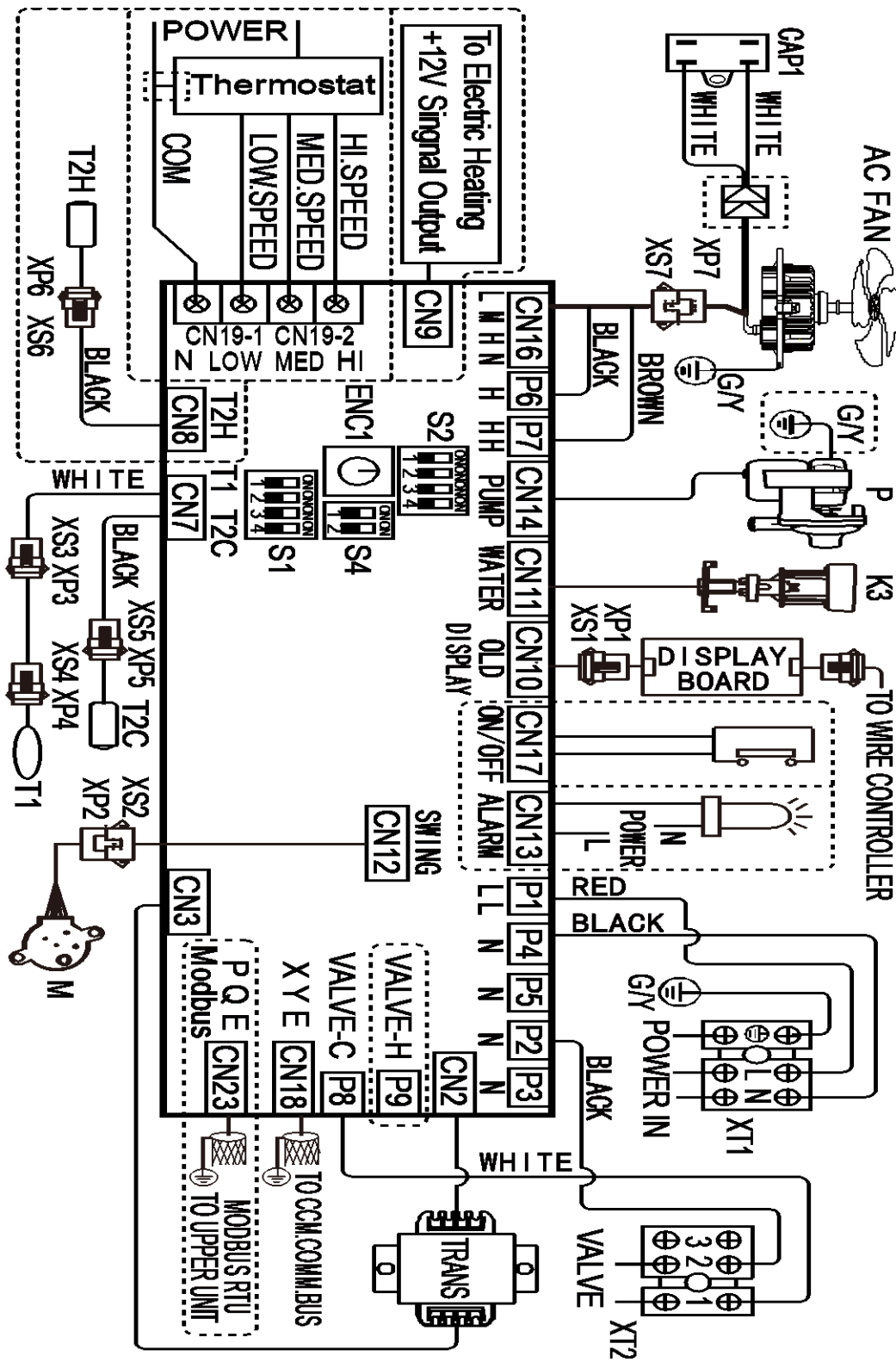

NOTE:

1.ALARM: Error codes or protections occurred , a closed signal output.
 2.ON/OFF : Short circuit, forced off; otherwise, all the controllers available.

S1	S1-1		2 pipe(default)	S2	S2-1/2		Temp.compensation value is 0 under cool mode(default)
			4 pipe				Temp.compensation value is 1 under cool mode
	S1-2		Without enforcement to turn wind(default)			Temp.compensation value is 2 under cool mode	
			With enforcement to turn wind			Temp.compensation value is 3 under cool mode	
	S1-3		Normal anti-cold wind(default)		S2-3/4		Temp.compensation value is 3 under heat mode(default)
			High temperature anti-cold wind				Temp.compensation value is 1 under heat mode
	S1-4		turn on E-heater and heating valve (default setting)				Temp.compensation value is 6 under heat mode
			turn on E-heater, turn off heating valve				Temp.compensation value is 8 under heat mode

WIRING DIAGRAM

CODE	PART NAME
CAP1	INDOOR FAN CAPACITOR
CN1-23,P1-9	P.C BOARD SOCKETS
AC FAN	INDOOR FAN MOTOR
K3	WATER LEVEL SWITCH
M	SWING MOTOR
P	PUMP
T1	ROOM TEMPERATURE
T2C/T2H	PIPE TEMPERATURE
XP1-7	CONNECTORS
XS1-7	CONNECTORS
XT1-2	3-WAY TERMINAL
TRANS	POWER TRANSFORMER

	0
	1

SWITCH FOR ADDRESS SETTING				Address 0-15
ENC1 & S4	'0-F' of the ENC1 and 'ON/OFF' of the S4, the different position represents a different address.Is be combined 64 address(0-63)			Address 16-31
				Address 32-47
				Address 48-63

11. Capacity Tables

Cooling Capacity:

Four-way cassette

MDVF-600C4E																						
EWT	ΔT	Indoor temp (W.B.)	Indoor temperature (D.B.)																			
			21				23				25				27				29			
°C	°C	°C	TC	SC	WF	WPD	TC	SC	WF	WPD	TC	SC	WF	WPD	TC	SC	WF	WPD	TC	SC	WF	WPD
			kW	kW	m ³ /h	kPa	kW	kW	m ³ /h	kPa	kW	kW	m ³ /h	kPa	kW	kW	m ³ /h	kPa	kW	kW	m ³ /h	kPa
5	3	15	4.78	3.78	1.37	24.14	4.73	4.35	1.36	23.73	4.91	4.91	1.41	25.33	5.46	5.46	1.56	30.04	6.01	6.01	1.72	35.45
		17	6.47	3.79	1.86	40.45	6.42	4.36	1.84	39.80	6.37	4.92	1.82	39.21	6.32	5.48	1.81	38.61	6.26	6.03	1.79	38.03
		19	-	-	-	-	8.25	4.38	2.38	62.15	8.18	4.94	2.34	60.44	8.12	5.50	2.33	59.70	8.06	6.05	2.31	58.97
		20	-	-	-	-	9.21	4.39	2.66	75.35	9.15	4.95	2.64	74.47	9.09	5.51	2.62	73.56	9.02	6.06	2.61	72.69
	4	15	4.02	3.44	0.86	10.84	4.01	4.01	0.86	10.80	4.58	4.58	0.98	13.53	5.15	5.15	1.11	16.66	5.70	5.70	1.23	19.81
		17	5.76	3.47	1.24	20.19	5.72	4.04	1.23	19.92	5.67	4.61	1.22	19.63	5.62	5.16	1.21	19.32	5.70	5.66	1.23	19.80
		19	-	-	-	-	7.53	4.05	1.62	31.64	7.47	4.62	1.60	31.24	7.42	5.18	1.59	30.86	7.37	5.73	1.58	30.48
		20	-	-	-	-	8.50	4.06	1.83	39.21	8.44	4.63	1.81	38.49	8.38	5.19	1.80	38.02	8.32	5.74	1.78	37.56
	5	15	3.32	3.13	0.57	4.26	3.69	3.69	0.63	5.62	4.25	4.25	0.73	7.92	4.82	4.82	0.83	10.04	5.38	5.38	0.92	12.09
		17	4.99	3.13	0.86	10.67	4.95	3.70	0.85	10.51	4.90	4.27	0.84	10.33	4.87	4.83	0.83	10.22	5.39	5.39	0.92	12.13
		19	-	-	-	-	6.81	3.73	1.17	18.22	6.76	4.30	1.17	17.99	6.71	4.86	1.16	17.76	6.66	5.42	1.15	17.52
		20	-	-	-	-	7.76	3.74	1.33	22.62	7.71	4.30	1.32	22.34	7.65	4.87	1.31	22.07	7.60	5.42	1.30	21.79
6	15	2.87	2.85	0.41	1.93	3.42	3.42	0.49	2.84	3.96	3.96	0.57	4.23	4.50	4.50	0.64	5.97	5.05	5.05	0.72	7.82	
	17	4.24	2.81	0.61	5.10	4.19	3.39	0.60	4.97	4.16	3.96	0.60	4.86	4.51	4.51	0.65	6.00	5.06	5.06	0.72	7.85	
	19	-	-	-	-	6.03	3.40	0.86	10.75	5.98	3.97	0.86	10.61	5.93	4.53	0.85	10.45	5.87	5.09	0.84	10.28	
	20	-	-	-	-	7.01	3.42	1.01	13.95	6.96	3.99	1.00	13.77	6.91	4.55	0.99	13.60	6.86	5.11	0.98	13.42	
7	3	15	3.45	3.19	0.99	13.54	3.77	3.77	1.09	15.94	4.34	4.34	1.25	20.25	4.89	4.89	1.40	24.58	5.45	5.45	1.58	29.98
		17	5.17	3.21	1.48	27.01	5.12	3.78	1.47	26.62	5.07	4.34	1.46	26.16	5.03	4.90	1.44	25.82	5.46	5.46	1.58	30.09
		19	-	-	-	-	6.94	3.79	1.99	45.01	6.89	4.36	1.98	44.45	6.84	4.92	1.97	43.89	6.79	5.47	1.95	43.27
		20	-	-	-	-	7.91	3.80	2.28	56.91	7.85	4.37	2.26	55.75	7.80	4.93	2.24	55.08	7.74	5.48	2.23	54.38
	4	15	2.85	2.81	0.61	5.33	3.44	3.44	0.74	8.20	4.01	4.01	0.86	10.71	4.58	4.58	0.99	13.47	5.14	5.14	1.11	16.38
		17	4.41	2.88	0.95	12.65	4.37	3.46	0.94	12.43	4.32	4.03	0.93	12.23	4.59	4.59	0.99	13.52	5.15	5.15	1.11	16.43
		19	-	-	-	-	6.20	3.47	1.33	22.38	6.15	4.04	1.32	22.09	6.10	4.60	1.31	21.77	6.04	5.16	1.30	21.42
		20	-	-	-	-	7.18	3.49	1.55	29.09	7.11	4.05	1.53	28.35	7.06	4.61	1.52	27.99	7.01	5.17	1.51	27.63
	5	15	2.59	2.59	0.45	2.29	3.13	3.13	0.54	3.80	3.68	3.68	0.63	5.84	4.25	4.25	0.73	7.97	4.81	4.81	0.83	9.89
		17	3.59	2.55	0.62	5.46	3.55	3.12	0.61	5.32	3.68	3.63	0.63	5.80	4.26	4.26	0.73	8.00	4.82	4.82	0.83	9.93
		19	-	-	-	-	5.41	3.15	0.93	12.07	5.36	3.72	0.92	11.89	5.26	4.33	0.95	29.90	5.26	4.84	0.90	11.51
		20	-	-	-	-	6.39	3.16	1.10	16.08	6.34	3.73	1.09	15.87	6.29	4.30	1.08	15.65	6.24	4.85	1.07	15.40
6	15	2.30	2.30	0.33	1.43	2.87	2.87	0.41	1.93	3.41	3.41	0.49	2.98	3.95	3.95	0.57	4.44	4.49	4.49	0.64	6.10	
	17	2.93	2.29	0.42	2.03	2.96	2.88	0.43	2.07	3.41	3.41	0.49	3.00	3.95	3.95	0.57	4.47	4.50	4.50	0.64	6.13	
	19	-	-	-	-	4.56	2.81	0.65	6.33	4.51	3.38	0.65	6.18	4.47	3.95	0.64	6.04	4.50	4.47	0.64	6.13	
	20	-	-	-	-	5.56	2.83	0.80	9.22	5.51	3.40	0.79	9.08	5.46	3.97	0.78	8.94	5.40	4.53	0.77	8.78	
9	3	15	2.60	2.60	0.75	8.26	3.18	3.18	0.91	11.63	3.76	3.76	1.08	15.50	4.32	4.32	1.24	19.56	4.88	4.88	1.40	24.10
		17	3.77	2.62	1.09	15.58	3.72	3.19	1.07	15.25	3.75	3.73	1.08	15.47	4.33	4.33	1.24	19.63	4.89	4.89	1.40	24.18
		19	-	-	-	-	5.57	3.21	1.61	30.74	5.53	3.78	1.60	30.30	5.48	4.35	1.58	29.80	5.43	4.90	1.57	29.34
		20	-	-	-	-	6.52	3.21	1.88	39.83	6.47	3.79	1.86	39.31	6.42	4.35	1.85	38.79	6.37	4.91	1.83	38.23
	4	15	2.30	2.30	0.50	3.14	2.85	2.85	0.61	5.50	3.43	3.43	0.74	8.05	4.00	4.00	0.86	10.46	4.57	4.57	0.99	13.23
		17	2.91	2.28	0.63	5.77	2.91	2.86	0.63	5.75	3.44	3.44	0.74	8.08	4.01	4.01	0.86	10.50	4.58	4.58	0.99	13.27
		19	-	-	-	-	4.76	2.89	1.03	14.12	4.72	3.46	1.02	13.94	4.68	4.03	1.01	13.76	4.66	4.59	1.01	13.69
		20	-	-	-	-	5.74	2.90	1.24	19.42	5.69	3.47	1.23	19.15	5.64	4.04	1.22	18.86	5.59	4.60	1.21	18.55
	5	15	2.02	2.02	0.35	1.45	2.58	2.58	0.44	2.34	3.12	3.12	0.54	3.93	3.68	3.68	0.63	5.95	4.24	4.24	0.73	7.87
		17	2.24	2.02	0.39	1.69	2.58	2.57	0.44	2.34	3.13	3.13	0.54	3.96	3.69	3.69	0.63	5.98	4.25	4.25	0.73	7.90
		19	-	-	-	-	3.88	2.55	0.67	6.69	3.84	3.13	0.66	6.53	3.82	3.69	0.66	6.45	4.26	4.26	0.73	7.93
		20	-	-	-	-	4.89	2.57	0.84	10.00	4.84	3.15	0.83	9.84	4.79	3.71	0.82	9.66	4.75	4.27	0.82	9.51
6	15	1.73	1.73	0.25	1.01	2.30	2.30	0.33	1.35	2.86	2.86	0.41	1.93	3.39	3.39	0.49	3.05	3.93	3.93	0.56	4.53	
	17	1.75	1.74	0.25	1.02	2.30	2.30	0.33	1.35	2.86	2.86	0.41	1.94	3.40	3.40	0.49	3.07	3.94	3.94	0.57	4.56	
	19	-	-	-	-	3.12	2.27	0.45	2.44	3.11	2.85	0.45	2.42	3.41	3.39	0.49	3.08	3.95	3.95	0.57	4.58	
	20	-	-	-	-	4.00	2.24	0.57	4.73	3.95	2.82	0.57	4.60	3.92	3.39	0.56	4.49	3.96	3.95	0.57	4.62	

Continue:

MDVF-600C4E																							
EWT	ΔT	Indoor temp (W.B.)	Indoor temperature (D.B.)																				
			21				23				25				27				29				
			TC	SC	WF	WPD	TC	SC	WF	WPD	TC	SC	WF	WPD	TC	SC	WF	WPD	TC	SC	WF	WPD	
°C	°C	°C	kW	kW	m³/h	kPa	kW	kW	m³/h	kPa	kW	kW	m³/h	kPa	kW	kW	m³/h	kPa	kW	kW	m³/h	kPa	
11	3	15	2.01	2.01	0.57	4.73	2.60	2.60	0.74	8.01	3.18	3.18	0.91	11.26	3.75	3.75	1.07	15.03	4.30	4.30	1.23	18.95	
		17	2.23	2.01	0.63	6.03	2.60	2.60	0.74	8.03	3.18	3.18	0.91	11.30	3.75	3.75	1.07	15.08	4.31	4.31	1.23	19.01	
		19	-	-	-	-	4.06	2.62	1.16	17.14	4.01	3.19	1.14	16.80	3.98	3.76	1.14	16.58	4.32	4.32	1.23	19.09	
		20	-	-	-	-	5.04	2.63	1.44	24.83	4.99	3.20	1.42	24.43	4.94	3.77	1.41	24.01	4.89	4.33	1.40	23.61	
	4	15	1.74	1.74	0.37	1.57	2.29	2.29	0.49	3.15	2.85	2.85	0.61	5.54	3.43	3.43	0.73	7.85	3.99	3.99	0.86	10.17	
		17	1.74	1.71	0.37	1.57	2.29	2.29	0.49	3.17	2.86	2.86	0.61	5.57	3.43	3.43	0.74	7.88	4.00	4.00	0.86	10.21	
		19	-	-	-	-	3.17	2.29	0.68	6.86	3.14	2.87	0.67	6.75	3.44	3.42	0.74	7.89	4.01	4.01	0.86	10.24	
		20	-	-	-	-	4.17	2.31	0.89	10.96	4.12	2.88	0.88	10.74	4.08	3.45	0.87	10.55	4.08	4.02	0.87	10.56	
	5	15	1.45	1.45	0.25	0.98	2.02	2.02	0.35	1.40	2.57	2.57	0.44	2.42	3.12	3.12	0.54	4.07	3.68	3.68	0.63	6.01	
		17	1.46	1.46	0.25	0.99	2.03	2.03	0.35	1.41	2.58	2.58	0.44	2.43	3.12	3.12	0.54	4.09	3.69	3.69	0.63	6.03	
		19	-	-	-	-	2.40	2.01	0.41	2.01	2.58	2.56	0.44	2.44	3.13	3.13	0.54	4.12	3.69	3.69	0.64	6.06	
		20	-	-	-	-	3.26	1.98	0.56	4.55	3.22	2.56	0.55	4.43	3.22	3.14	0.56	4.44	3.70	3.70	0.64	6.07	
	6	15	1.17	1.17	0.17	0.64	1.73	1.73	0.25	0.96	2.30	2.30	0.33	1.29	2.85	2.85	0.41	1.97	3.38	3.38	0.49	3.15	
		17	1.17	1.17	0.17	0.65	1.74	1.74	0.25	0.96	2.30	2.30	0.33	1.29	2.85	2.85	0.41	1.99	3.39	3.39	0.49	3.17	
		19	-	-	-	-	1.79	1.76	0.26	0.99	2.31	2.31	0.33	1.29	2.86	2.86	0.41	2.00	3.40	3.40	0.49	3.19	
		20	-	-	-	-	2.50	1.72	0.36	1.47	2.52	2.31	0.36	1.49	2.86	2.85	0.41	2.00	3.40	3.40	0.49	3.20	
	13	3	15	1.45	1.45	0.42	2.07	2.01	2.01	0.58	4.94	2.60	2.60	0.75	7.98	3.17	3.17	0.91	11.20	3.73	3.73	1.06	14.60
			17	1.45	1.45	0.42	2.08	2.02	2.02	0.58	4.96	2.60	2.60	0.75	8.00	3.18	3.18	0.91	11.24	3.74	3.74	1.07	14.65
			19	-	-	-	-	2.43	2.03	0.70	7.15	2.58	2.52	0.74	7.90	3.18	3.18	0.91	11.28	3.75	3.75	1.08	14.93
			20	-	-	-	-	3.41	2.03	0.98	12.58	3.38	2.62	0.97	12.48	3.36	3.19	0.97	12.39	3.76	3.75	1.08	14.96
		4	15	1.17	1.17	0.25	0.95	1.74	1.74	0.37	1.59	2.28	2.28	0.49	3.30	2.84	2.84	0.61	5.57	3.42	3.42	0.73	7.69
			17	1.17	1.17	0.25	0.95	1.74	1.74	0.37	1.59	2.29	2.29	0.49	3.32	2.85	2.85	0.61	5.59	3.42	3.42	0.73	7.72
			19	-	-	-	-	1.75	1.74	0.38	1.62	2.29	2.29	0.49	3.34	2.86	2.86	0.61	5.62	3.43	3.43	0.74	7.75
			20	-	-	-	-	2.47	1.71	0.53	4.06	2.46	2.29	0.53	4.03	2.86	2.85	0.61	5.63	3.44	3.44	0.74	7.77
5		15	0.88	0.88	0.15	0.56	1.45	1.45	0.25	0.93	2.01	2.01	0.35	1.36	2.56	2.56	0.44	2.45	3.11	3.11	0.53	4.12	
		17	0.88	0.88	0.15	0.56	1.45	1.45	0.25	0.93	2.02	2.02	0.35	1.36	2.56	2.56	0.44	2.47	3.11	3.11	0.53	4.14	
		19	-	-	-	-	1.45	1.45	0.25	0.93	2.02	2.02	0.35	1.37	2.57	2.57	0.44	2.48	3.12	3.12	0.54	4.16	
		20	-	-	-	-	1.70	1.45	0.29	1.09	2.03	2.01	0.35	1.37	2.57	2.57	0.44	2.49	3.12	3.12	0.54	4.17	
6		15	0.59	0.59	0.08	0.31	1.16	1.16	0.17	0.61	1.73	1.73	0.25	0.91	2.29	2.29	0.33	1.24	2.84	2.84	0.41	2.01	
		17	0.59	0.59	0.08	0.31	1.17	1.17	0.17	0.61	1.73	1.73	0.25	0.91	2.30	2.30	0.33	1.24	2.84	2.84	0.41	2.02	
		19	-	-	-	-	1.17	1.17	0.17	0.61	1.74	1.74	0.25	0.91	2.30	2.30	0.33	1.25	2.85	2.85	0.41	2.03	
		20	-	-	-	-	1.19	1.18	0.17	0.62	1.74	1.74	0.25	0.91	2.31	2.31	0.33	1.25	2.85	2.85	0.41	2.04	
15		3	15	0.87	0.87	0.25	0.92	1.44	1.44	0.41	2.08	2.01	2.01	0.57	4.90	2.59	2.59	0.74	7.72	3.16	3.16	0.90	10.83
			17	0.88	0.88	0.25	0.92	1.44	1.44	0.41	2.09	2.01	2.01	0.57	4.92	2.59	2.59	0.74	7.74	3.16	3.16	0.90	10.87
			19	-	-	-	-	1.45	1.45	0.41	2.10	2.01	2.01	0.57	4.94	2.60	2.60	0.74	7.77	3.17	3.17	0.90	10.91
			20	-	-	-	-	1.67	1.44	0.48	3.08	2.01	1.99	0.57	4.94	2.60	2.60	0.74	7.79	3.17	3.17	0.91	10.93
		4	15	0.59	0.59	0.13	0.45	1.16	1.16	0.25	0.90	1.73	1.73	0.37	1.59	2.28	2.28	0.49	3.34	2.84	2.84	0.61	5.54
			17	0.59	0.59	0.13	0.45	1.17	1.17	0.25	0.90	1.73	1.73	0.37	1.59	2.28	2.28	0.49	3.36	2.85	2.85	0.61	5.57
			19	-	-	-	-	1.17	1.17	0.25	0.90	1.74	1.74	0.37	1.60	2.29	2.29	0.49	3.38	2.86	2.86	0.61	5.59
			20	-	-	-	-	1.17	1.13	0.25	0.90	1.74	1.74	0.37	1.61	2.29	2.29	0.49	3.39	2.86	2.86	0.61	5.60
	5	15	0.30	0.30	0.05	0.18	0.88	0.88	0.15	0.54	1.45	1.45	0.25	0.89	2.01	2.01	0.35	1.37	2.55	2.55	0.44	2.57	
		17	0.30	0.30	0.05	0.18	0.88	0.88	0.15	0.54	1.45	1.45	0.25	0.89	2.02	2.02	0.35	1.37	2.56	2.56	0.44	2.58	
		19	-	-	-	-	0.88	0.88	0.15	0.54	1.46	1.46	0.25	0.89	2.02	2.02	0.35	1.38	2.56	2.56	0.44	2.60	
		20	-	-	-	-	0.88	0.88	0.15	0.54	1.46	1.46	0.25	0.89	2.02	2.02	0.35	1.38	2.57	2.57	0.44	2.60	
	6	15	-	-	-	-	0.59	0.59	0.09	0.29	1.16	1.16	0.17	0.58	1.73	1.73	0.25	0.87	2.29	2.29	0.33	1.23	
		17	-	-	-	-	0.59	0.59	0.09	0.30	1.17	1.17	0.17	0.58	1.73	1.73	0.25	0.87	2.29	2.29	0.33	1.23	
		19	-	-	-	-	0.60	0.60	0.09	0.30	1.17	1.17	0.17	0.58	1.74	1.74	0.25	0.87	2.30	2.30	0.33	1.24	
		20	-	-	-	-	0.60	0.60	0.09	0.30	1.17	1.17	0.17	0.58	1.74	1.74	0.25	0.87	2.30	2.30	0.33	1.24	

Cooling Capacity

MDVF-750C4E																							
EWT	ΔT	Indoor temp (W.B.)	Indoor temperature (D.B.)																				
			21				23				25				27				29				
			TC	SC	WF	WPD	TC	SC	WF	WPD	TC	SC	WF	WPD	TC	SC	WF	WPD	TC	SC	WF	WPD	
°C	°C	°C	kW	kW	m ³ /h	kPa	kW	kW	m ³ /h	kPa	kW	kW	m ³ /h	kPa	kW	kW	m ³ /h	kPa	kW	kW	m ³ /h	kPa	
5	3	15	5.06	4.05	1.45	26.57	5.02	4.68	1.44	26.28	5.29	5.29	1.51	28.41	5.90	5.90	1.69	34.34	6.51	6.51	1.87	40.93	
		17	6.91	4.06	1.98	45.41	6.86	4.68	1.96	44.53	6.81	5.30	1.95	44.01	6.76	5.91	1.94	43.47	6.71	6.52	1.92	42.83	
		19	-	-	-	-	8.83	4.69	2.53	69.19	8.78	5.31	2.52	68.42	8.72	5.93	2.50	67.70	8.68	6.54	2.50	67.72	
		20	-	-	-	-	9.88	4.70	2.84	84.22	9.82	5.32	2.82	83.32	9.76	5.93	2.80	82.45	9.70	6.54	2.78	81.56	
	4	15	4.19	3.66	0.90	11.63	4.27	4.24	0.91	12.03	4.91	4.91	1.05	15.26	5.54	5.54	1.19	18.88	6.14	6.14	1.32	22.41	
		17	6.09	3.69	1.31	22.20	6.05	4.32	1.30	21.95	6.01	4.94	1.29	21.68	5.95	5.55	1.28	21.32	6.15	6.14	1.32	22.40	
		19	-	-	-	-	8.02	4.32	1.72	35.32	7.97	4.95	1.71	34.93	7.92	5.56	1.70	34.55	7.87	6.17	1.69	34.16	
		20	-	-	-	-	9.07	4.33	1.95	43.73	9.02	4.95	1.94	43.24	8.96	5.57	1.92	42.78	8.90	6.18	1.91	42.31	
	5	15	3.39	3.30	0.58	4.49	3.90	3.90	0.67	6.48	4.53	4.53	0.78	9.00	5.15	5.15	0.88	11.28	5.77	5.77	0.99	13.67	
		17	5.19	3.30	0.89	11.42	5.15	3.93	0.88	11.27	5.10	4.55	0.87	11.07	5.15	5.13	0.88	11.26	5.78	5.78	0.99	13.71	
		19	-	-	-	-	7.19	3.96	1.24	20.01	7.14	4.59	1.23	19.78	7.09	5.20	1.22	19.55	7.04	5.81	1.21	19.32	
		20	-	-	-	-	8.23	3.96	1.41	25.02	8.17	4.59	1.40	24.74	8.12	5.20	1.39	24.46	8.07	5.82	1.38	24.19	
6	15	3.02	3.01	0.43	2.12	3.60	3.60	0.52	3.26	4.18	4.18	0.60	4.91	4.78	4.78	0.68	6.90	5.40	5.40	0.77	8.89		
	17	4.31	2.93	0.62	5.31	4.26	3.56	0.61	5.17	4.26	4.19	0.61	5.15	4.79	4.79	0.69	6.93	5.41	5.41	0.77	8.92		
	19	-	-	-	-	6.28	3.58	0.90	11.60	6.23	4.20	0.89	11.39	6.18	4.82	0.89	11.24	6.12	5.43	0.88	11.06		
	20	-	-	-	-	7.36	3.60	1.06	15.16	7.31	4.22	1.05	14.98	7.26	4.84	1.04	14.81	7.21	5.46	1.03	14.64		
7	3	15	3.62	3.41	1.04	14.71	4.05	4.05	1.17	18.02	4.66	4.66	1.34	22.68	5.29	5.29	1.53	28.50	5.90	5.90	1.70	34.37	
		17	5.51	3.43	1.59	30.56	5.47	4.06	1.58	30.19	5.42	4.68	1.57	29.72	5.39	5.30	1.56	29.41	5.91	5.91	1.71	34.43	
		19	-	-	-	-	7.44	4.07	2.15	51.27	7.38	4.69	2.12	50.11	7.33	5.30	2.11	49.54	7.28	5.91	2.09	48.96	
		20	-	-	-	-	8.48	4.07	2.44	63.84	8.43	4.70	2.43	63.39	8.38	5.32	2.42	62.91	8.32	5.93	2.40	62.06	
	4	15	3.03	3.02	0.65	6.20	3.66	3.66	0.79	9.21	4.30	4.30	0.93	12.13	4.92	4.92	1.06	15.26	5.53	5.53	1.19	18.44	
		17	4.62	3.06	1.00	13.71	4.58	3.69	0.99	13.48	4.54	4.31	0.98	13.27	4.93	4.93	1.07	15.31	5.54	5.54	1.19	18.49	
		19	-	-	-	-	6.57	3.70	1.41	24.78	6.53	4.33	1.40	24.49	6.48	4.94	1.39	24.20	6.42	5.55	1.38	23.83	
		20	-	-	-	-	7.64	3.71	1.65	32.42	7.59	4.34	1.64	32.06	7.54	4.96	1.63	31.69	7.49	5.57	1.62	31.33	
	5	15	2.73	2.73	0.47	2.60	3.31	3.31	0.57	4.40	3.91	3.91	0.67	6.73	4.54	4.54	0.78	8.99	5.17	5.17	0.89	11.17	
		17	3.65	2.67	0.63	5.70	3.61	3.30	0.62	5.55	3.92	3.91	0.67	6.75	4.55	4.55	0.78	9.02	5.17	5.17	0.89	11.21	
		19	-	-	-	-	5.66	3.33	0.97	13.05	5.62	3.96	0.97	12.88	5.58	4.68	1.00	30.00	5.52	5.19	0.95	12.49	
		20	-	-	-	-	6.72	3.34	1.16	17.50	6.68	3.97	1.15	17.35	6.64	4.59	1.14	17.18	6.59	5.20	1.14	16.96	
6	15	2.43	2.43	0.35	1.52	3.03	3.03	0.44	2.18	3.60	3.60	0.52	3.45	4.18	4.18	0.60	5.10	4.79	4.79	0.69	7.03		
	17	2.96	2.40	0.43	2.07	3.08	3.04	0.44	2.26	3.61	3.61	0.52	3.47	4.19	4.19	0.60	5.12	4.80	4.80	0.69	7.06		
	19	-	-	-	-	4.66	2.94	0.67	6.64	4.62	3.57	0.66	6.49	4.57	4.19	0.65	6.34	4.80	4.77	0.69	7.06		
	20	-	-	-	-	5.76	2.96	0.83	9.82	5.72	3.59	0.82	9.70	5.67	4.21	0.81	9.56	5.61	4.83	0.80	9.39		
9	3	15	2.78	2.78	0.80	9.23	3.41	3.41	0.98	13.11	4.04	4.04	1.16	17.47	4.66	4.66	1.34	22.32	5.28	5.28	1.53	28.01	
		17	3.98	2.79	1.15	17.10	3.93	3.42	1.13	16.74	4.03	4.00	1.16	17.41	4.67	4.67	1.34	22.39	5.29	5.29	1.53	28.10	
		19	-	-	-	-	5.92	3.43	1.70	33.71	5.88	4.06	1.69	33.31	5.83	4.68	1.68	32.85	5.77	5.29	1.66	32.29	
		20	-	-	-	-	6.99	3.45	2.03	45.55	6.94	4.07	2.01	45.01	6.90	4.69	2.00	44.47	6.85	5.31	1.98	43.93	
	4	15	2.43	2.43	0.52	3.63	3.03	3.03	0.65	6.33	3.67	3.67	0.79	9.05	4.30	4.30	0.93	11.83	4.92	4.92	1.06	14.87	
		17	2.97	2.40	0.64	6.04	3.03	3.01	0.65	6.33	3.68	3.68	0.79	9.08	4.31	4.31	0.93	11.87	4.93	4.93	1.06	14.92	
		19	-	-	-	-	5.01	3.07	1.08	15.34	4.96	3.70	1.07	15.11	4.91	4.32	1.06	14.82	4.95	4.94	1.07	15.06	
		20	-	-	-	-	6.07	3.08	1.31	21.42	6.03	3.71	1.30	21.15	5.98	4.33	1.29	20.89	5.93	4.95	1.28	20.56	
	5	15	2.13	2.13	0.37	1.56	2.72	2.72	0.47	2.70	3.31	3.31	0.57	4.57	3.92	3.92	0.68	6.83	4.55	4.55	0.78	8.88	
		17	2.28	2.13	0.39	1.74	2.73	2.72	0.47	2.71	3.31	3.31	0.57	4.59	3.93	3.93	0.68	6.85	4.56	4.56	0.79	8.91	
		19	-	-	-	-	3.99	2.68	0.69	7.05	3.94	3.31	0.68	6.87	3.97	3.95	0.68	6.99	4.57	4.57	0.79	8.94	
		20	-	-	-	-	5.10	2.71	0.88	10.75	5.05	3.34	0.87	10.60	5.00	3.96	0.86	10.40	4.95	4.58	0.85	10.24	
6	15	1.82	1.82	0.26	1.07	2.43	2.43	0.35	1.44	3.02	3.02	0.43	2.22	3.60	3.60	0.52	3.55	4.19	4.19	0.60	5.28		
	17	1.83	1.82	0.26	1.07	2.43	2.43	0.35	1.45	3.03	3.03	0.43	2.23	3.60	3.60	0.52	3.57	4.19	4.19	0.60	5.30		
	19	-	-	-	-	3.15	2.38	0.45	2.48	3.17	3.02	0.45	2.53	3.61	3.60	0.52	3.58	4.20	4.20	0.60	5.33		
	20	-	-	-	-	4.06	2.33	0.58	4.88	4.01	2.96	0.58	4.75	3.97	3.59	0.57	4.64	4.20	4.18	0.60	5.32		

Continue:

MDVF-750C4E																							
EWT	ΔT	Indoor temp (W.B.)	Indoor temperature (D.B.)																				
			21				23				25				27				29				
			TC	SC	WF	WPD	TC	SC	WF	WPD	TC	SC	WF	WPD	TC	SC	WF	WPD	TC	SC	WF	WPD	
°C	°C	°C	kW	kW	m³/h	kPa	kW	kW	m³/h	kPa	kW	kW	m³/h	kPa	kW	kW	m³/h	kPa	kW	kW	m³/h	kPa	
11	3	15	2.13	2.13	0.61	5.45	2.78	2.78	0.79	8.99	3.41	3.41	0.97	12.75	4.04	4.04	1.15	16.99	4.65	4.65	1.33	21.70	
		17	2.28	2.14	0.65	6.35	2.78	2.78	0.79	9.02	3.42	3.42	0.97	12.79	4.04	4.04	1.15	17.04	4.66	4.66	1.33	21.76	
		19	-	-	-	-	4.30	2.80	1.23	18.94	4.25	3.43	1.21	18.54	4.22	4.05	1.20	18.35	4.67	4.67	1.33	21.83	
		20	-	-	-	-	5.36	2.81	1.54	27.83	5.32	3.44	1.52	27.39	5.27	4.06	1.51	26.89	5.21	4.68	1.49	26.36	
	4	15	1.84	1.84	0.39	1.76	2.42	2.42	0.52	3.66	3.04	3.04	0.65	6.35	3.68	3.68	0.79	8.85	4.30	4.30	0.92	11.55	
		17	1.84	1.82	0.39	1.75	2.43	2.43	0.52	3.67	3.05	3.05	0.65	6.38	3.68	3.68	0.79	8.88	4.31	4.31	0.92	11.58	
		19	-	-	-	-	3.26	2.42	0.70	7.24	3.24	3.05	0.69	7.15	3.69	3.68	0.79	8.90	4.32	4.32	0.92	11.62	
		20	-	-	-	-	4.37	2.44	0.94	11.88	4.33	3.07	0.93	11.66	4.27	3.70	0.92	11.43	4.34	4.33	0.93	11.74	
	5	15	1.53	1.53	0.26	1.04	2.14	2.14	0.37	1.54	2.72	2.72	0.47	2.81	3.32	3.32	0.57	4.75	3.94	3.94	0.68	6.83	
		17	1.53	1.53	0.26	1.04	2.15	2.15	0.37	1.55	2.73	2.73	0.47	2.83	3.32	3.32	0.57	4.77	3.95	3.95	0.68	6.86	
		19	-	-	-	-	2.43	2.12	0.42	2.06	2.73	2.71	0.47	2.83	3.33	3.33	0.57	4.79	3.95	3.95	0.68	6.88	
		20	-	-	-	-	3.30	2.07	0.57	4.71	3.26	2.70	0.56	4.56	3.35	3.34	0.58	4.86	3.96	3.96	0.68	6.89	
6	15	1.22	1.22	0.17	0.68	1.83	1.83	0.26	1.02	2.44	2.44	0.35	1.41	3.02	3.02	0.43	2.30	3.60	3.60	0.52	3.70		
	17	1.22	1.22	0.18	0.68	1.83	1.83	0.26	1.02	2.44	2.44	0.35	1.41	3.02	3.02	0.43	2.31	3.60	3.60	0.52	3.71		
	19	-	-	-	-	1.87	1.85	0.27	1.04	2.45	2.45	0.35	1.41	3.03	3.03	0.43	2.32	3.61	3.61	0.52	3.73		
	20	-	-	-	-	2.51	1.80	0.36	1.48	2.58	2.44	0.37	1.56	3.03	3.02	0.43	2.32	3.61	3.61	0.52	3.74		
13	3	15	1.53	1.53	0.44	2.40	2.14	2.14	0.62	5.68	2.79	2.79	0.80	9.00	3.41	3.41	0.97	12.54	4.04	4.04	1.16	16.95	
		17	1.54	1.54	0.44	2.41	2.15	2.15	0.62	5.71	2.79	2.79	0.80	9.03	3.41	3.41	0.97	12.57	4.04	4.04	1.16	17.00	
		19	-	-	-	-	2.52	2.16	0.72	7.57	2.78	2.75	0.80	8.99	3.42	3.42	0.98	12.61	4.05	4.05	1.16	17.06	
		20	-	-	-	-	3.59	2.16	1.02	13.68	3.54	2.80	1.01	13.34	3.54	3.43	1.01	13.37	4.06	4.05	1.17	17.08	
	4	15	1.23	1.23	0.26	1.01	1.84	1.84	0.40	1.82	2.42	2.42	0.52	3.86	3.05	3.05	0.65	6.33	3.68	3.68	0.79	8.72	
		17	1.23	1.23	0.27	1.01	1.84	1.84	0.40	1.83	2.43	2.43	0.52	3.88	3.05	3.05	0.65	6.35	3.68	3.68	0.79	8.74	
		19	-	-	-	-	1.85	1.84	0.40	1.85	2.43	2.43	0.52	3.89	3.06	3.06	0.65	6.37	3.69	3.69	0.79	8.77	
		20	-	-	-	-	2.49	1.79	0.54	4.16	2.52	2.44	0.54	4.25	3.06	3.06	0.66	6.38	3.69	3.69	0.79	8.79	
	5	15	0.92	0.92	0.16	0.59	1.53	1.53	0.26	0.98	2.14	2.14	0.37	1.53	2.71	2.71	0.47	2.87	3.31	3.31	0.57	4.80	
		17	0.92	0.92	0.16	0.59	1.53	1.53	0.26	0.98	2.14	2.14	0.37	1.53	2.72	2.72	0.47	2.89	3.32	3.32	0.57	4.82	
		19	-	-	-	-	1.53	1.53	0.26	0.99	2.14	2.14	0.37	1.54	2.72	2.72	0.47	2.90	3.32	3.32	0.57	4.84	
		20	-	-	-	-	1.71	1.52	0.29	1.10	2.14	2.13	0.37	1.54	2.73	2.73	0.47	2.91	3.33	3.33	0.57	4.85	
6	15	0.61	0.61	0.09	0.32	1.22	1.22	0.17	0.64	1.83	1.83	0.26	0.97	2.44	2.44	0.35	1.38	3.01	3.01	0.43	2.35		
	17	0.61	0.61	0.09	0.32	1.22	1.22	0.18	0.64	1.84	1.84	0.26	0.97	2.44	2.44	0.35	1.39	3.02	3.02	0.43	2.36		
	19	-	-	-	-	1.23	1.23	0.18	0.65	1.84	1.84	0.26	0.97	2.45	2.45	0.35	1.39	3.02	3.02	0.43	2.37		
	20	-	-	-	-	1.24	1.23	0.18	0.65	1.84	1.84	0.26	0.97	2.45	2.45	0.35	1.39	3.02	3.02	0.43	2.38		
15	3	15	0.92	0.92	0.26	0.97	1.52	1.52	0.43	2.42	2.14	2.14	0.61	5.60	2.78	2.78	0.79	8.74	3.41	3.41	0.97	12.36	
		17	0.92	0.92	0.26	0.97	1.53	1.53	0.44	2.43	2.15	2.15	0.61	5.62	2.79	2.79	0.80	8.77	3.41	3.41	0.97	12.39	
		19	-	-	-	-	1.53	1.53	0.44	2.44	2.15	2.15	0.61	5.64	2.79	2.79	0.80	8.80	3.42	3.42	0.98	12.43	
		20	-	-	-	-	1.68	1.52	0.48	3.15	2.15	2.14	0.61	5.64	2.80	2.80	0.80	8.81	3.42	3.42	0.98	12.45	
	4	15	0.62	0.62	0.13	0.48	1.23	1.23	0.26	0.95	1.83	1.83	0.39	1.85	2.42	2.42	0.52	3.92	3.05	3.05	0.65	6.27	
		17	0.62	0.62	0.13	0.48	1.23	1.23	0.26	0.96	1.84	1.84	0.39	1.86	2.43	2.43	0.52	3.93	3.06	3.06	0.66	6.29	
		19	-	-	-	-	1.23	1.23	0.26	0.96	1.84	1.84	0.39	1.87	2.43	2.43	0.52	3.95	3.06	3.06	0.66	6.31	
		20	-	-	-	-	1.23	1.21	0.26	0.96	1.84	1.84	0.39	1.87	2.43	2.43	0.52	3.96	3.07	3.07	0.66	6.32	
	5	15	0.31	0.31	0.05	0.19	0.93	0.93	0.16	0.57	1.54	1.54	0.26	0.94	2.14	2.14	0.37	1.58	2.72	2.72	0.47	3.02	
		17	0.31	0.31	0.05	0.19	0.93	0.93	0.16	0.57	1.54	1.54	0.27	0.95	2.14	2.14	0.37	1.59	2.72	2.72	0.47	3.04	
		19	-	-	-	-	0.93	0.93	0.16	0.57	1.54	1.54	0.27	0.95	2.15	2.15	0.37	1.60	2.73	2.73	0.47	3.05	
		20	-	-	-	-	0.93	0.93	0.16	0.57	1.54	1.54	0.27	0.95	2.15	2.15	0.37	1.60	2.73	2.73	0.47	3.06	
6	15	-	-	-	-	0.62	0.62	0.09	0.31	1.23	1.23	0.18	0.62	1.84	1.84	0.26	0.92	2.44	2.44	0.35	1.41		
	17	-	-	-	-	0.62	0.62	0.09	0.31	1.23	1.23	0.18	0.62	1.84	1.84	0.26	0.93	2.44	2.44	0.35	1.41		
	19	-	-	-	-	0.62	0.62	0.09	0.31	1.23	1.23	0.18	0.62	1.85	1.85	0.26	0.93	2.45	2.45	0.35	1.42		
	20	-	-	-	-	0.62	0.62	0.09	0.31	1.24	1.24	0.18	0.62	1.85	1.85	0.27	0.93	2.45	2.45	0.35	1.42		

Cooling Capacity

MDVF-850C4E																						
EWT	ΔT	Indoor temp (W.B.)	Indoor temperature (D.B.)																			
			21				23				25				27				29			
			TC	SC	WF	WPD	TC	SC	WF	WPD	TC	SC	WF	WPD	TC	SC	WF	WPD	TC	SC	WF	WPD
°C	°C	°C	kW	kW	m ³ /h	kPa	kW	kW	m ³ /h	kPa	kW	kW	m ³ /h	kPa	kW	kW	m ³ /h	kPa	kW	kW	m ³ /h	kPa
5	3	15	5.52	4.49	1.59	15.50	5.46	5.19	1.57	15.19	5.89	5.89	1.68	17.06	6.59	6.59	1.90	20.95	7.28	7.28	2.09	24.83
		17	7.62	4.50	2.18	26.68	7.57	5.21	2.17	26.47	7.53	5.91	2.17	26.28	7.48	6.61	2.15	25.98	7.41	7.29	2.13	25.57
		19	-	-	-	-	9.82	5.23	2.82	41.34	9.76	5.93	2.80	40.89	9.69	6.62	2.78	40.34	9.63	7.31	2.76	39.79
		20	-	-	-	-	11.01	5.24	3.18	50.77	10.95	5.94	3.16	50.23	10.88	6.64	3.14	49.69	10.81	7.32	3.12	49.17
	4	15	4.46	4.02	0.96	5.72	4.72	4.72	1.02	6.62	5.42	5.42	1.17	9.07	6.12	6.12	1.31	11.14	6.82	6.82	1.46	13.37
		17	6.57	4.03	1.41	12.55	6.52	4.74	1.40	12.39	6.47	5.44	1.39	12.23	6.40	6.14	1.37	12.00	6.83	6.83	1.46	13.41
		19	-	-	-	-	8.82	4.78	1.90	20.90	8.76	5.48	1.89	20.67	8.70	6.18	1.88	20.44	8.64	6.87	1.86	20.21
		20	-	-	-	-	9.99	4.78	2.14	25.67	9.93	5.48	2.13	25.39	9.86	6.18	2.11	25.11	9.80	6.87	2.10	24.83
	5	15	3.75	3.70	0.64	2.10	4.36	4.36	0.75	2.96	5.01	5.01	0.86	4.31	5.67	5.67	0.97	5.97	6.35	6.35	1.09	7.85
		17	5.49	3.57	0.94	5.50	5.46	4.29	0.94	5.45	5.41	5.00	0.93	5.30	5.68	5.68	0.97	5.99	6.36	6.36	1.09	7.88
		19	-	-	-	-	7.71	4.30	1.32	11.24	7.66	5.01	1.31	11.11	7.61	5.71	1.30	10.97	7.55	6.40	1.29	10.84
		20	-	-	-	-	8.94	4.32	1.53	14.43	8.88	5.03	1.52	14.26	8.82	5.73	1.51	14.10	8.76	6.42	1.50	13.94
6	15	3.33	3.32	0.48	1.46	4.01	4.01	0.57	1.77	4.68	4.68	0.67	2.27	5.33	5.33	0.76	3.13	5.97	5.97	0.85	4.27	
	17	4.75	3.26	0.68	2.34	4.71	3.98	0.67	2.29	4.72	4.69	0.67	2.31	5.33	5.33	0.76	3.14	5.98	5.98	0.85	4.29	
	19	-	-	-	-	6.62	3.85	0.95	5.65	6.57	4.56	0.94	5.55	6.53	5.26	0.93	5.45	6.47	5.96	0.93	5.32	
	20	-	-	-	-	7.78	3.85	1.11	8.24	7.72	4.55	1.11	8.12	7.67	5.26	1.10	8.00	7.62	5.95	1.09	7.89	
7	3	15	3.84	3.75	1.10	8.05	4.47	4.47	1.28	10.59	5.19	5.19	1.49	13.61	5.90	5.90	1.70	17.13	6.59	6.59	1.90	20.71
		17	6.03	3.80	1.74	17.78	5.98	4.51	1.73	17.56	5.93	5.21	1.71	17.28	5.91	5.90	1.71	17.18	6.60	6.60	1.91	20.77
		19	-	-	-	-	8.23	4.52	2.38	30.39	8.18	5.23	2.36	30.03	8.13	5.93	2.35	29.70	8.07	6.62	2.33	29.37
		20	-	-	-	-	9.42	4.53	2.72	38.33	9.36	5.24	2.71	37.91	9.30	5.94	2.69	37.49	9.24	6.63	2.67	37.07
	4	15	3.38	3.38	0.73	2.79	4.04	4.04	0.87	4.56	4.72	4.72	1.02	6.82	5.43	5.43	1.17	9.02	6.14	6.14	1.32	11.09
		17	4.87	3.31	1.05	7.32	4.82	4.03	1.04	7.15	4.78	4.73	1.03	7.01	5.44	5.44	1.17	9.05	6.15	6.15	1.32	11.13
		19	-	-	-	-	7.16	4.07	1.55	14.49	7.11	4.78	1.54	14.32	7.06	5.48	1.53	14.14	7.00	6.17	1.51	13.93
		20	-	-	-	-	8.34	4.08	1.79	18.63	8.29	4.78	1.78	18.41	8.23	5.49	1.77	18.20	8.17	6.18	1.76	17.99
	5	15	3.03	3.03	0.52	1.54	3.71	3.71	0.64	2.06	4.36	4.36	0.75	3.08	5.01	5.01	0.86	4.50	5.68	5.68	0.98	6.22
		17	4.02	2.97	0.69	2.50	3.98	3.69	0.69	2.43	4.36	4.36	0.75	3.09	5.02	5.02	0.86	4.52	5.69	5.69	0.98	6.24
		19	-	-	-	-	5.96	3.59	1.03	6.96	5.92	4.30	1.02	6.84	5.87	5.10	1.06	35.00	5.80	5.70	1.00	6.55
		20	-	-	-	-	7.20	3.62	1.24	9.88	7.15	4.33	1.23	9.76	7.10	5.03	1.22	9.63	7.04	5.72	1.21	9.51
6	15	2.66	2.66	0.38	1.11	3.34	3.34	0.48	1.39	4.02	4.02	0.58	1.72	4.68	4.68	0.67	2.35	5.32	5.32	0.77	3.31	
	17	3.14	2.63	0.45	1.31	3.35	3.33	0.48	1.39	4.03	4.03	0.58	1.73	4.69	4.69	0.67	2.36	5.33	5.33	0.77	3.32	
	19	-	-	-	-	5.07	3.25	0.73	2.91	5.03	3.96	0.72	2.84	4.99	4.67	0.72	2.78	5.34	5.33	0.77	3.33	
	20	-	-	-	-	6.06	3.17	0.87	4.65	6.02	3.89	0.86	4.57	5.97	4.60	0.86	4.48	5.93	5.31	0.85	4.44	
9	3	15	3.05	3.05	0.88	4.77	3.76	3.76	1.08	7.76	4.48	4.48	1.29	10.46	5.19	5.19	1.49	13.41	5.89	5.89	1.70	16.74
		17	4.26	3.06	1.22	9.59	4.20	3.78	1.20	9.36	4.49	4.48	1.29	10.48	5.20	5.20	1.49	13.45	5.90	5.90	1.70	16.79
		19	-	-	-	-	6.50	3.80	1.87	19.70	6.45	4.51	1.85	19.45	6.40	5.21	1.84	19.19	6.33	5.91	1.82	18.83
		20	-	-	-	-	7.72	3.82	2.23	26.79	7.64	4.52	2.19	26.01	7.59	5.22	2.18	25.70	7.54	5.92	2.16	25.40
	4	15	2.72	2.72	0.59	1.74	3.38	3.38	0.73	2.95	4.04	4.04	0.87	4.72	4.73	4.73	1.02	6.90	5.44	5.44	1.17	8.87
		17	3.25	2.68	0.70	2.66	3.36	3.32	0.73	2.92	4.04	4.04	0.87	4.74	4.74	4.74	1.02	6.92	5.45	5.45	1.17	8.90
		19	-	-	-	-	5.34	3.35	1.15	8.58	5.29	4.06	1.14	8.45	5.22	4.76	1.12	8.26	5.45	5.41	1.17	8.88
		20	-	-	-	-	6.56	3.37	1.41	12.19	6.52	4.08	1.40	12.04	6.47	4.78	1.39	11.88	6.40	5.48	1.38	11.68
	5	15	2.34	2.34	0.40	1.12	3.03	3.03	0.52	1.46	3.70	3.70	0.64	2.08	4.35	4.35	0.75	3.20	5.01	5.01	0.86	4.68
		17	2.41	2.34	0.42	1.16	3.03	3.03	0.52	1.46	3.71	3.71	0.64	2.09	4.36	4.36	0.75	3.21	5.02	5.02	0.86	4.70
		19	-	-	-	-	4.27	2.95	0.74	3.06	4.23	3.67	0.73	2.96	4.34	4.30	0.75	3.19	5.02	5.02	0.86	4.72
		20	-	-	-	-	5.32	2.90	0.92	5.46	5.28	3.61	0.91	5.36	5.22	4.32	0.90	5.21	5.18	5.02	0.89	5.10
6	15	1.98	1.98	0.28	0.78	2.67	2.67	0.38	1.05	3.35	3.35	0.48	1.31	4.02	4.02	0.58	1.68	4.67	4.67	0.67	2.40	
	17	1.98	1.97	0.28	0.78	2.67	2.67	0.38	1.05	3.35	3.35	0.48	1.32	4.03	4.03	0.58	1.69	4.68	4.68	0.67	2.41	
	19	-	-	-	-	3.40	2.64	0.49	1.33	3.44	3.36	0.49	1.35	4.04	4.04	0.58	1.69	4.69	4.69	0.67	2.42	
	20	-	-	-	-	4.45	2.58	0.64	2.11	4.40	3.30	0.63	2.06	4.37	4.02	0.63	2.02	4.69	4.67	0.67	2.42	

Continue:

MDVF-850C4E																							
EWT	ΔT	Indoor temp (W.B.)	Indoor temperature (D.B.)																				
			21				23				25				27				29				
			TC	SC	WF	WPD	TC	SC	WF	WPD	TC	SC	WF	WPD	TC	SC	WF	WPD	TC	SC	WF	WPD	
°C	°C	°C	kW	kW	m³/h	kPa	kW	kW	m³/h	kPa	kW	kW	m³/h	kPa	kW	kW	m³/h	kPa	kW	kW	m³/h	kPa	
11	3	15	2.38	2.38	0.68	2.47	3.05	3.05	0.87	4.85	3.77	3.77	1.07	7.58	4.48	4.48	1.28	10.18	5.19	5.19	1.48	13.04	
		17	2.47	2.37	0.70	2.74	3.06	3.06	0.87	4.87	3.78	3.78	1.08	7.61	4.49	4.49	1.28	10.21	5.20	5.20	1.48	13.07	
		19	-	-	-	-	4.64	3.08	1.32	10.79	4.58	3.79	1.31	10.55	4.56	4.50	1.30	10.46	5.20	5.20	1.48	13.11	
		20	-	-	-	-	5.85	3.09	1.67	16.00	5.80	3.81	1.65	15.78	5.75	4.51	1.64	15.53	5.69	5.22	1.63	15.36	
	4	15	2.02	2.02	0.43	1.16	2.71	2.71	0.58	1.70	3.37	3.37	0.72	2.97	4.04	4.04	0.86	4.82	4.74	4.74	1.02	6.84	
		17	2.02	2.01	0.43	1.16	2.72	2.72	0.58	1.70	3.37	3.37	0.72	2.99	4.05	4.05	0.87	4.84	4.75	4.75	1.02	6.86	
		19	-	-	-	-	3.46	2.66	0.74	3.19	3.45	3.37	0.74	3.17	4.05	4.05	0.87	4.86	4.75	4.75	1.02	6.89	
		20	-	-	-	-	4.59	2.63	0.98	6.44	4.54	3.35	0.97	6.29	4.47	4.06	0.96	6.10	4.75	4.71	1.02	6.85	
	5	15	1.67	1.67	0.29	0.76	2.36	2.36	0.41	1.07	3.04	3.04	0.52	1.41	3.70	3.70	0.64	2.15	4.35	4.35	0.75	3.34	
		17	1.67	1.67	0.29	0.76	2.36	2.36	0.41	1.07	3.05	3.05	0.52	1.42	3.71	3.71	0.64	2.16	4.36	4.36	0.75	3.35	
		19	-	-	-	-	2.60	2.35	0.45	1.18	3.05	3.03	0.52	1.42	3.72	3.72	0.64	2.17	4.36	4.36	0.75	3.37	
		20	-	-	-	-	3.62	2.30	0.62	2.03	3.58	3.02	0.62	1.97	3.72	3.70	0.64	2.17	4.37	4.37	0.75	3.38	
6	15	1.32	1.32	0.19	0.49	2.00	2.00	0.29	0.74	2.68	2.68	0.38	1.00	3.36	3.36	0.48	1.26	4.03	4.03	0.58	1.70		
	17	1.32	1.32	0.19	0.49	2.00	2.00	0.29	0.74	2.68	2.68	0.38	1.00	3.36	3.36	0.48	1.26	4.03	4.03	0.58	1.70		
	19	-	-	-	-	2.00	1.99	0.29	0.74	2.69	2.69	0.39	1.00	3.37	3.37	0.48	1.26	4.04	4.04	0.58	1.71		
	20	-	-	-	-	2.63	1.96	0.38	0.98	2.75	2.70	0.39	1.02	3.37	3.37	0.48	1.26	4.05	4.05	0.58	1.71		
13	3	15	1.71	1.71	0.49	1.28	2.38	2.38	0.68	2.63	3.06	3.06	0.88	5.10	3.78	3.78	1.09	7.60	4.49	4.49	1.29	10.17	
		17	1.71	1.71	0.49	1.28	2.38	2.38	0.68	2.64	3.07	3.07	0.88	5.12	3.79	3.79	1.09	7.62	4.50	4.50	1.29	10.20	
		19	-	-	-	-	2.64	2.37	0.76	3.48	3.07	3.07	0.88	5.14	3.79	3.79	1.09	7.65	4.51	4.51	1.29	10.23	
		20	-	-	-	-	3.84	2.37	1.10	7.81	3.78	3.09	1.09	7.60	3.81	3.81	1.09	7.68	4.51	4.51	1.30	10.25	
	4	15	1.34	1.34	0.29	0.74	2.03	2.03	0.44	1.11	2.72	2.72	0.58	1.75	3.37	3.37	0.73	3.14	4.05	4.05	0.87	5.02	
		17	1.34	1.34	0.29	0.74	2.04	2.04	0.44	1.12	2.72	2.72	0.59	1.76	3.37	3.37	0.73	3.15	4.05	4.05	0.87	5.04	
		19	-	-	-	-	2.03	2.00	0.44	1.11	2.72	2.72	0.59	1.77	3.38	3.38	0.73	3.17	4.06	4.06	0.87	5.06	
		20	-	-	-	-	2.74	2.00	0.59	1.79	2.78	2.73	0.60	1.86	3.38	3.38	0.73	3.17	4.07	4.07	0.88	5.07	
	5	15	0.99	0.99	0.17	0.42	1.67	1.67	0.29	0.72	2.35	2.35	0.40	1.01	3.04	3.04	0.52	1.37	3.69	3.69	0.63	2.19	
		17	0.99	0.99	0.17	0.42	1.67	1.67	0.29	0.72	2.36	2.36	0.40	1.01	3.04	3.04	0.52	1.38	3.70	3.70	0.63	2.20	
		19	-	-	-	-	1.68	1.68	0.29	0.72	2.36	2.36	0.41	1.01	3.05	3.05	0.52	1.38	3.70	3.70	0.63	2.21	
		20	-	-	-	-	1.78	1.67	0.31	0.76	2.36	2.35	0.41	1.01	3.05	3.05	0.52	1.38	3.70	3.70	0.64	2.22	
6	15	0.65	0.65	0.09	0.23	1.32	1.32	0.19	0.46	2.00	2.00	0.29	0.70	2.68	2.68	0.38	0.94	3.36	3.36	0.48	1.20		
	17	0.65	0.65	0.09	0.23	1.33	1.33	0.19	0.47	2.01	2.01	0.29	0.71	2.69	2.69	0.38	0.95	3.37	3.37	0.48	1.21		
	19	-	-	-	-	1.33	1.33	0.19	0.47	2.01	2.01	0.29	0.71	2.69	2.69	0.39	0.95	3.37	3.37	0.48	1.21		
	20	-	-	-	-	1.32	1.31	0.19	0.47	2.01	2.01	0.29	0.71	2.69	2.69	0.39	0.95	3.38	3.38	0.48	1.21		
15	3	15	1.01	1.01	0.29	0.71	1.70	1.70	0.49	1.21	2.37	2.37	0.68	2.66	3.06	3.06	0.87	5.08	3.78	3.78	1.08	7.39	
		17	1.01	1.01	0.29	0.71	1.71	1.71	0.49	1.22	2.37	2.37	0.68	2.67	3.06	3.06	0.87	5.10	3.79	3.79	1.08	7.41	
		19	-	-	-	-	1.71	1.71	0.49	1.22	2.38	2.38	0.68	2.68	3.07	3.07	0.88	5.12	3.79	3.79	1.08	7.43	
		20	-	-	-	-	1.85	1.70	0.53	1.40	2.38	2.38	0.68	2.69	3.07	3.07	0.88	5.13	3.80	3.80	1.08	7.44	
	4	15	0.66	0.66	0.14	0.34	1.35	1.35	0.29	0.70	2.03	2.03	0.44	1.05	2.71	2.71	0.58	1.77	3.36	3.36	0.72	3.20	
		17	0.66	0.66	0.14	0.34	1.35	1.35	0.29	0.70	2.04	2.04	0.44	1.06	2.71	2.71	0.58	1.78	3.37	3.37	0.72	3.21	
		19	-	-	-	-	1.35	1.35	0.29	0.70	2.04	2.04	0.44	1.06	2.72	2.72	0.58	1.79	3.37	3.37	0.72	3.23	
		20	-	-	-	-	1.35	1.32	0.29	0.70	2.04	2.04	0.44	1.06	2.72	2.72	0.58	1.79	3.38	3.38	0.72	3.24	
	5	15	0.33	0.33	0.06	0.13	1.00	1.00	0.17	0.41	1.68	1.68	0.29	0.69	2.37	2.37	0.41	0.97	3.05	3.05	0.52	1.39	
		17	0.33	0.33	0.06	0.13	1.00	1.00	0.17	0.41	1.69	1.69	0.29	0.69	2.37	2.37	0.41	0.97	3.05	3.05	0.53	1.40	
		19	-	-	-	-	1.00	1.00	0.17	0.41	1.69	1.69	0.29	0.69	2.38	2.38	0.41	0.97	3.06	3.06	0.53	1.40	
		20	-	-	-	-	1.01	1.01	0.17	0.41	1.69	1.69	0.29	0.69	2.38	2.38	0.41	0.98	3.06	3.06	0.53	1.41	
6	15	-	-	-	-	0.66	0.66	0.09	0.22	1.33	1.33	0.19	0.45	2.01	2.01	0.29	0.68	2.69	2.69	0.39	0.91		
	17	-	-	-	-	0.66	0.66	0.09	0.22	1.34	1.34	0.19	0.45	2.02	2.02	0.29	0.68	2.70	2.70	0.39	0.91		
	19	-	-	-	-	0.66	0.66	0.09	0.22	1.34	1.34	0.19	0.45	2.02	2.02	0.29	0.68	2.70	2.70	0.39	0.91		
	20	-	-	-	-	0.66	0.66	0.10	0.22	1.34	1.34	0.19	0.45	2.02	2.02	0.29	0.68	2.70	2.70	0.39	0.91		

Cooling Capacity

MDVF-950C4E																						
EWT	ΔT	Indoor temp (W.B.)	Indoor temperature (D.B.)																			
			21				23				25				27				29			
			TC	SC	WF	WPD	TC	SC	WF	WPD	TC	SC	WF	WPD	TC	SC	WF	WPD	TC	SC	WF	WPD
°C	°C	°C	kW	kW	m³/h	kPa	kW	kW	m³/h	kPa	kW	kW	m³/h	kPa	kW	kW	m³/h	kPa	kW	kW	m³/h	kPa
5	3	15	5.71	4.66	1.63	16.24	5.67	5.41	1.63	16.18	6.14	6.14	1.75	18.34	6.88	6.88	1.98	22.56	7.60	7.60	2.18	26.60
		17	7.91	4.68	2.26	28.31	7.86	5.42	2.25	27.99	7.81	6.16	2.23	27.67	7.75	6.89	2.22	27.35	7.69	7.61	2.20	27.09
		19	-	-	-	-	10.21	5.44	2.92	44.00	10.15	6.18	2.90	43.54	10.09	6.91	2.89	43.09	10.03	7.63	2.87	42.64
		20	-	-	-	-	11.46	5.45	3.28	53.72	11.39	6.18	3.26	53.14	11.32	6.91	3.24	52.59	11.25	7.64	3.22	52.05
	4	15	4.58	4.17	0.99	6.12	4.90	4.90	1.06	7.27	5.65	5.65	1.22	9.79	6.38	6.38	1.37	11.96	7.12	7.12	1.52	14.38
		17	6.80	4.19	1.46	13.32	6.76	4.93	1.45	13.17	6.71	5.67	1.44	13.01	6.63	6.40	1.42	12.76	7.13	7.13	1.53	14.42
		19	-	-	-	-	9.16	4.97	1.97	22.32	9.10	5.71	1.96	22.08	9.04	6.44	1.95	21.84	8.99	7.16	1.94	21.61
		20	-	-	-	-	10.39	4.97	2.23	27.44	10.32	5.71	2.21	27.15	10.26	6.44	2.20	26.86	10.20	7.17	2.19	26.59
	5	15	3.86	3.84	0.66	2.22	4.52	4.52	0.78	3.25	5.20	5.20	0.89	4.75	5.89	5.89	1.01	6.57	6.62	6.62	1.13	8.56
		17	5.64	3.69	0.97	5.87	5.60	4.44	0.96	5.77	5.54	5.18	0.95	5.61	5.90	5.90	1.01	6.60	6.63	6.63	1.14	8.58
		19	-	-	-	-	7.99	4.47	1.37	11.92	7.93	5.21	1.36	11.79	7.88	5.94	1.35	11.65	7.82	6.67	1.34	11.51
		20	-	-	-	-	9.29	4.50	1.60	15.53	9.23	5.24	1.59	15.36	9.17	5.97	1.58	15.19	9.11	6.70	1.57	15.02
6	15	3.45	3.45	0.49	1.52	4.15	4.15	0.59	1.85	4.85	4.85	0.69	2.46	5.52	5.52	0.79	3.44	6.19	6.19	0.89	4.72	
	17	4.85	3.37	0.69	2.46	4.81	4.12	0.69	2.40	4.87	4.87	0.70	2.48	5.53	5.53	0.79	3.46	6.20	6.20	0.89	4.74	
	19	-	-	-	-	6.79	3.97	0.97	6.02	6.74	4.72	0.97	5.93	6.70	5.46	0.96	5.82	6.63	6.19	0.95	5.68	
	20	-	-	-	-	8.03	3.98	1.15	8.76	7.97	4.72	1.14	8.64	7.92	5.46	1.13	8.53	7.86	6.19	1.13	8.41	
7	3	15	3.97	3.90	1.14	8.61	4.66	4.66	1.34	11.36	5.41	5.41	1.55	14.63	6.16	6.16	1.78	18.45	6.87	6.87	1.97	22.00
		17	6.26	3.95	1.81	18.96	6.21	4.70	1.79	18.73	6.16	5.43	1.78	18.44	6.16	6.14	1.78	18.44	6.88	6.88	1.97	22.06
		19	-	-	-	-	8.57	4.71	2.48	32.55	8.51	5.45	2.46	32.19	8.46	6.19	2.44	31.83	8.40	6.91	2.43	31.47
		20	-	-	-	-	9.80	4.71	2.83	40.85	9.75	5.46	2.82	40.71	9.69	6.19	2.80	40.27	9.63	6.92	2.79	39.84
	4	15	3.50	3.50	0.75	3.07	4.19	4.19	0.90	5.03	4.92	4.92	1.06	7.45	5.67	5.67	1.22	9.70	6.41	6.41	1.38	12.00
		17	5.02	3.43	1.08	7.81	4.97	4.18	1.07	7.64	4.94	4.92	1.07	7.55	5.68	5.68	1.22	9.72	6.42	6.42	1.39	12.03
		19	-	-	-	-	7.43	4.23	1.61	15.43	7.38	4.98	1.59	15.24	7.33	5.71	1.58	15.06	7.26	6.44	1.57	14.84
		20	-	-	-	-	8.67	4.24	1.86	19.88	8.61	4.98	1.85	19.66	8.55	5.72	1.84	19.44	8.50	6.45	1.83	19.22
	5	15	3.14	3.14	0.54	1.60	3.84	3.84	0.66	2.22	4.51	4.51	0.78	3.39	5.20	5.20	0.89	4.97	5.91	5.91	1.02	6.82
		17	4.10	3.07	0.70	2.61	4.06	3.82	0.70	2.55	4.52	4.52	0.78	3.40	5.21	5.21	0.90	4.99	5.92	5.92	1.02	6.85
		19	-	-	-	-	6.14	3.72	1.06	7.42	6.10	4.46	1.05	7.30	6.09	5.40	1.10	27.14	5.99	5.93	1.03	7.03
		20	-	-	-	-	7.45	3.75	1.28	10.47	7.40	4.49	1.27	10.34	7.35	5.23	1.26	10.21	7.29	5.96	1.25	10.09
6	15	2.75	2.75	0.40	1.15	3.46	3.46	0.50	1.44	4.17	4.17	0.60	1.83	4.85	4.85	0.70	2.57	5.52	5.52	0.79	3.65	
	17	3.20	2.72	0.46	1.33	3.46	3.45	0.50	1.44	4.18	4.18	0.60	1.83	4.86	4.86	0.70	2.58	5.53	5.53	0.79	3.66	
	19	-	-	-	-	5.18	3.35	0.74	3.07	5.13	4.10	0.74	3.00	5.10	4.84	0.73	2.94	5.54	5.54	0.80	3.68	
	20	-	-	-	-	6.20	3.27	0.89	4.95	6.16	4.02	0.88	4.86	6.12	4.76	0.88	4.77	6.05	5.50	0.87	4.64	
9	3	15	3.17	3.17	0.91	5.26	3.92	3.92	1.12	8.34	4.68	4.68	1.34	11.24	5.42	5.42	1.56	14.45	6.15	6.15	1.76	17.90
		17	4.41	3.19	1.26	10.17	4.34	3.93	1.25	9.92	4.68	4.67	1.34	11.26	5.43	5.43	1.56	14.49	6.16	6.16	1.77	17.95
		19	-	-	-	-	6.75	3.96	1.94	21.04	6.71	4.70	1.93	20.78	6.65	5.44	1.91	20.51	6.58	6.17	1.89	20.13
		20	-	-	-	-	8.03	3.98	2.32	28.67	7.97	4.72	2.31	28.34	7.92	5.46	2.29	28.01	7.87	6.19	2.28	27.69
	4	15	2.81	2.81	0.61	1.86	3.50	3.50	0.76	3.25	4.19	4.19	0.90	5.20	4.93	4.93	1.06	7.48	5.68	5.68	1.22	9.53
		17	3.32	2.77	0.72	2.81	3.49	3.45	0.75	3.22	4.20	4.20	0.90	5.22	4.94	4.94	1.06	7.50	5.69	5.69	1.22	9.56
		19	-	-	-	-	5.52	3.47	1.19	9.08	5.47	4.22	1.18	8.94	5.39	4.96	1.16	8.74	5.69	5.67	1.22	9.57
		20	-	-	-	-	6.83	3.51	1.48	13.16	6.75	4.24	1.45	12.80	6.70	4.98	1.44	12.64	6.64	5.71	1.43	12.43
	5	15	2.42	2.42	0.42	1.16	3.14	3.14	0.54	1.52	3.84	3.84	0.66	2.27	4.51	4.51	0.78	3.53	5.20	5.20	0.90	5.16
		17	2.48	2.43	0.43	1.19	3.14	3.14	0.54	1.53	3.84	3.84	0.66	2.28	4.52	4.52	0.78	3.55	5.21	5.21	0.90	5.18
		19	-	-	-	-	4.36	3.04	0.75	3.23	4.31	3.80	0.74	3.13	4.51	4.48	0.78	3.53	5.22	5.22	0.90	5.20
		20	-	-	-	-	5.46	2.99	0.94	5.81	5.42	3.74	0.93	5.70	5.36	4.49	0.92	5.55	5.33	5.22	0.92	5.46
6	15	2.05	2.05	0.29	0.80	2.76	2.76	0.40	1.08	3.47	3.47	0.50	1.37	4.17	4.17	0.60	1.81	4.84	4.84	0.69	2.64	
	17	2.05	2.04	0.29	0.80	2.76	2.76	0.40	1.09	3.48	3.48	0.50	1.37	4.18	4.18	0.60	1.82	4.85	4.85	0.70	2.65	
	19	-	-	-	-	3.46	2.72	0.50	1.36	3.54	3.49	0.51	1.40	4.19	4.19	0.60	1.82	4.86	4.86	0.70	2.66	
	20	-	-	-	-	4.53	2.66	0.65	2.21	4.49	3.42	0.64	2.16	4.46	4.16	0.64	2.13	4.86	4.85	0.70	2.67	

Continue:

MDVF-950C4E																						
EWT	ΔT	Indoor temp (W.B.)	Indoor temperature (D.B.)																			
			21				23				25				27				29			
			TC	SC	WF	WPD	TC	SC	WF	WPD	TC	SC	WF	WPD	TC	SC	WF	WPD	TC	SC	WF	WPD
°C	°C	°C	kW	kW	m ³ /h	kPa	kW	kW	m ³ /h	kPa	kW	kW	m ³ /h	kPa	kW	kW	m ³ /h	kPa	kW	kW	m ³ /h	kPa
11	3	15	2.46	2.46	0.70	2.72	3.17	3.17	0.90	5.33	3.93	3.93	1.12	8.14	4.68	4.68	1.33	10.94	5.42	5.42	1.55	14.20
		17	2.52	2.46	0.72	2.92	3.18	3.18	0.90	5.35	3.94	3.94	1.12	8.16	4.69	4.69	1.34	10.97	5.43	5.43	1.56	14.24
		19	-	-	-	-	4.81	3.21	1.37	11.46	4.74	3.95	1.35	11.21	4.73	4.70	1.35	11.16	5.44	5.44	1.56	14.27
		20	-	-	-	-	6.07	3.22	1.73	17.06	6.02	3.97	1.72	16.84	5.97	4.71	1.70	16.58	5.90	5.44	1.68	16.25
	4	15	2.10	2.10	0.45	1.21	2.81	2.81	0.60	1.84	3.49	3.49	0.75	3.28	4.20	4.20	0.90	5.30	4.95	4.95	1.06	7.37
		17	2.10	2.09	0.45	1.21	2.82	2.82	0.60	1.84	3.50	3.50	0.75	3.29	4.21	4.21	0.90	5.32	4.95	4.95	1.06	7.39
		19	-	-	-	-	3.53	2.75	0.76	3.37	3.54	3.50	0.76	3.40	4.21	4.21	0.90	5.35	4.97	4.97	1.06	7.41
		20	-	-	-	-	4.73	2.73	1.01	6.82	4.68	3.48	1.00	6.67	4.61	4.22	0.99	6.48	4.96	4.93	1.06	7.39
	5	15	1.72	1.72	0.30	0.78	2.44	2.44	0.42	1.11	3.16	3.16	0.54	1.50	3.84	3.84	0.66	2.37	4.52	4.52	0.78	3.69
		17	1.73	1.73	0.30	0.78	2.44	2.44	0.42	1.11	3.16	3.16	0.54	1.50	3.84	3.84	0.66	2.38	4.52	4.52	0.78	3.71
		19	-	-	-	-	2.65	2.43	0.46	1.20	3.16	3.15	0.54	1.50	3.85	3.85	0.66	2.39	4.53	4.53	0.78	3.72
		20	-	-	-	-	3.69	2.37	0.63	2.13	3.65	3.12	0.63	2.07	3.85	3.83	0.66	2.39	4.53	4.53	0.78	3.73
6	15	1.35	1.35	0.19	0.50	2.06	2.06	0.30	0.77	2.77	2.77	0.40	1.03	3.49	3.49	0.50	1.31	4.18	4.18	0.60	1.85	
	17	1.36	1.36	0.19	0.50	2.07	2.07	0.30	0.77	2.78	2.78	0.40	1.04	3.49	3.49	0.50	1.32	4.18	4.18	0.60	1.86	
	19	-	-	-	-	2.07	2.05	0.30	0.77	2.78	2.78	0.40	1.04	3.50	3.50	0.50	1.32	4.19	4.19	0.60	1.87	
	20	-	-	-	-	2.66	2.03	0.38	0.99	2.83	2.79	0.41	1.05	3.50	3.50	0.50	1.32	4.19	4.19	0.60	1.87	
13	3	15	1.77	1.77	0.51	1.34	2.47	2.47	0.71	2.90	3.19	3.19	0.92	5.58	3.95	3.95	1.13	8.17	4.69	4.69	1.35	10.95
		17	1.77	1.77	0.51	1.34	2.47	2.47	0.71	2.91	3.19	3.19	0.92	5.60	3.95	3.95	1.13	8.19	4.70	4.70	1.35	10.98
		19	-	-	-	-	2.69	2.46	0.77	3.69	3.20	3.20	0.92	5.61	3.96	3.96	1.14	8.21	4.70	4.70	1.35	11.01
		20	-	-	-	-	3.97	2.46	1.14	8.27	3.91	3.21	1.12	8.04	3.96	3.95	1.14	8.21	4.71	4.71	1.35	11.03
	4	15	1.39	1.39	0.30	0.76	2.11	2.11	0.45	1.16	2.81	2.81	0.61	1.92	3.50	3.50	0.75	3.47	4.21	4.21	0.90	5.41
		17	1.39	1.39	0.30	0.76	2.11	2.11	0.45	1.16	2.82	2.82	0.61	1.93	3.50	3.50	0.75	3.48	4.21	4.21	0.90	5.43
		19	-	-	-	-	2.10	2.08	0.45	1.16	2.82	2.82	0.61	1.93	3.51	3.51	0.76	3.50	4.22	4.22	0.90	5.45
		20	-	-	-	-	2.79	2.07	0.60	1.88	2.85	2.83	0.61	1.99	3.51	3.51	0.76	3.51	4.23	4.23	0.91	5.46
	5	15	1.01	1.01	0.17	0.43	1.73	1.73	0.30	0.74	2.44	2.44	0.42	1.05	3.15	3.15	0.54	1.47	3.83	3.83	0.66	2.42
		17	1.02	1.02	0.17	0.44	1.73	1.73	0.30	0.74	2.44	2.44	0.42	1.05	3.16	3.16	0.54	1.48	3.83	3.83	0.66	2.43
		19	-	-	-	-	1.73	1.73	0.30	0.74	2.45	2.45	0.42	1.05	3.16	3.16	0.54	1.48	3.84	3.84	0.66	2.44
		20	-	-	-	-	1.81	1.73	0.31	0.78	2.45	2.44	0.42	1.05	3.17	3.17	0.54	1.49	3.84	3.84	0.66	2.45
6	15	0.66	0.66	0.09	0.23	1.36	1.36	0.19	0.48	2.07	2.07	0.30	0.73	2.78	2.78	0.40	0.98	3.49	3.49	0.50	1.27	
	17	0.66	0.66	0.10	0.23	1.37	1.37	0.20	0.48	2.07	2.07	0.30	0.73	2.78	2.78	0.40	0.98	3.50	3.50	0.50	1.28	
	19	-	-	-	-	1.37	1.37	0.20	0.48	2.08	2.08	0.30	0.73	2.79	2.79	0.40	0.98	3.50	3.50	0.50	1.28	
	20	-	-	-	-	1.36	1.35	0.20	0.48	2.08	2.08	0.30	0.73	2.79	2.79	0.40	0.98	3.50	3.50	0.50	1.28	
15	3	15	1.04	1.04	0.30	0.73	1.77	1.77	0.50	1.28	2.46	2.46	0.70	2.93	3.19	3.19	0.91	5.52	3.94	3.94	1.13	7.94
		17	1.04	1.04	0.30	0.73	1.77	1.77	0.50	1.29	2.46	2.46	0.70	2.95	3.20	3.20	0.91	5.54	3.95	3.95	1.13	7.97
		19	-	-	-	-	1.77	1.77	0.51	1.29	2.46	2.46	0.70	2.96	3.20	3.20	0.91	5.56	3.96	3.96	1.13	7.99
		20	-	-	-	-	1.89	1.76	0.54	1.47	2.47	2.47	0.70	2.97	3.20	3.20	0.91	5.57	3.96	3.96	1.13	8.00
	4	15	0.68	0.68	0.15	0.35	1.39	1.39	0.30	0.72	2.11	2.11	0.45	1.10	2.81	2.81	0.60	1.95	3.49	3.49	0.75	3.54
		17	0.68	0.68	0.15	0.35	1.39	1.39	0.30	0.72	2.11	2.11	0.45	1.10	2.81	2.81	0.60	1.96	3.50	3.50	0.75	3.55
		19	-	-	-	-	1.40	1.40	0.30	0.72	2.12	2.12	0.45	1.10	2.81	2.81	0.60	1.97	3.50	3.50	0.75	3.57
		20	-	-	-	-	1.39	1.37	0.30	0.72	2.12	2.12	0.45	1.10	2.82	2.82	0.60	1.97	3.51	3.51	0.75	3.58
	5	15	0.33	0.33	0.06	0.14	1.03	1.03	0.18	0.42	1.74	1.74	0.30	0.71	2.46	2.46	0.42	1.01	3.16	3.16	0.54	1.52
		17	0.33	0.33	0.06	0.14	1.03	1.03	0.18	0.42	1.74	1.74	0.30	0.72	2.46	2.46	0.42	1.01	3.16	3.16	0.55	1.52
		19	-	-	-	-	1.03	1.03	0.18	0.42	1.75	1.75	0.30	0.72	2.46	2.46	0.42	1.01	3.17	3.17	0.55	1.53
		20	-	-	-	-	1.04	1.04	0.18	0.42	1.75	1.75	0.30	0.72	2.47	2.47	0.43	1.01	3.17	3.17	0.55	1.53
6	15	-	-	-	-	0.68	0.68	0.10	0.23	1.38	1.38	0.20	0.46	2.08	2.08	0.30	0.70	2.79	2.79	0.40	0.94	
	17	-	-	-	-	0.68	0.68	0.10	0.23	1.38	1.38	0.20	0.46	2.09	2.09	0.30	0.70	2.80	2.80	0.40	0.94	
	19	-	-	-	-	0.68	0.68	0.10	0.23	1.38	1.38	0.20	0.46	2.09	2.09	0.30	0.70	2.80	2.80	0.40	0.94	
	20	-	-	-	-	0.68	0.68	0.10	0.23	1.38	1.38	0.20	0.46	2.09	2.09	0.30	0.70	2.81	2.81	0.40	0.94	

Cooling Capacity

MDVF-1200C4E																						
EWT	ΔT	Indoor temp (W.B.)	Indoor temperature (D.B.)																			
			21				23				25				27				29			
			TC	SC	WF	WPD	TC	SC	WF	WPD	TC	SC	WF	WPD	TC	SC	WF	WPD	TC	SC	WF	WPD
°C	°C	°C	kW	kW	m ³ /h	kPa	kW	kW	m ³ /h	kPa	kW	kW	m ³ /h	kPa	kW	kW	m ³ /h	kPa	kW	kW	m ³ /h	kPa
5	3	15	6.51	5.23	1.87	20.49	6.44	6.04	1.85	20.12	6.84	6.84	1.97	22.33	7.63	7.63	2.19	26.77	8.42	8.42	2.41	31.51
		17	8.90	5.24	2.54	34.66	8.84	6.05	2.53	34.26	8.78	6.86	2.51	33.87	8.72	7.65	2.49	33.46	8.64	8.43	2.47	32.92
		19	-	-	-	-	11.41	6.07	3.27	53.30	11.34	6.87	3.25	52.70	11.26	7.67	3.22	52.11	11.19	8.46	3.20	51.55
		20	-	-	-	-	12.80	6.09	3.69	65.93	12.72	6.89	3.67	65.21	12.64	7.69	3.65	64.50	12.56	8.48	3.62	63.80
	4	15	5.31	4.70	1.14	8.71	5.50	5.47	1.19	9.33	6.33	6.33	1.36	11.78	7.13	7.13	1.53	14.44	7.94	7.94	1.71	17.47
		17	7.80	4.75	1.68	16.97	7.75	5.56	1.67	16.76	7.69	6.37	1.66	16.55	7.61	7.16	1.64	16.25	7.95	7.95	1.71	17.53
		19	-	-	-	-	10.31	5.57	2.21	27.09	10.25	6.38	2.20	26.80	10.18	7.18	2.18	26.48	10.11	7.97	2.17	26.19
		20	-	-	-	-	11.68	5.58	2.51	33.59	11.61	6.39	2.49	33.22	11.54	7.19	2.47	32.86	11.46	7.98	2.46	32.50
	5	15	4.40	4.30	0.76	3.03	5.05	5.05	0.87	4.42	5.82	5.82	1.00	6.39	6.62	6.62	1.14	8.57	7.43	7.43	1.27	10.54
		17	6.55	4.20	1.12	8.39	6.50	5.02	1.11	8.26	6.43	5.83	1.10	8.07	6.62	6.58	1.13	8.55	7.44	7.44	1.28	10.57
		19	-	-	-	-	9.19	5.09	1.58	15.24	9.13	5.90	1.57	15.06	9.07	6.70	1.56	14.89	8.98	7.48	1.54	14.53
		20	-	-	-	-	10.57	5.10	1.82	19.34	10.50	5.91	1.81	19.12	10.43	6.71	1.80	18.91	10.36	7.51	1.79	18.69
6	15	3.90	3.88	0.56	1.71	4.68	4.68	0.67	2.27	5.43	5.43	0.78	3.30	6.17	6.17	0.88	4.69	6.94	6.94	0.99	6.37	
	17	5.56	3.79	0.80	3.53	5.51	4.62	0.79	3.44	5.51	5.43	0.79	3.44	6.18	6.18	0.88	4.72	6.95	6.95	1.00	6.40	
	19	-	-	-	-	7.92	4.55	1.13	8.53	7.86	5.37	1.13	8.41	7.80	6.17	1.12	8.28	7.72	6.96	1.11	8.11	
	20	-	-	-	-	9.34	4.59	1.34	11.39	9.28	5.40	1.33	11.26	9.21	6.20	1.32	11.12	9.15	7.00	1.31	10.99	
7	3	15	4.60	4.39	1.32	11.10	5.22	5.22	1.49	13.73	6.04	6.04	1.74	17.84	6.83	6.83	1.96	21.75	7.62	7.62	2.19	26.26
		17	7.05	4.42	2.02	22.99	7.00	5.24	2.01	22.71	6.94	6.04	1.99	22.35	6.90	6.84	1.98	22.13	7.63	7.63	2.19	26.34
		19	-	-	-	-	9.60	5.26	2.78	39.64	9.54	6.07	2.76	39.18	9.47	6.87	2.74	38.71	9.41	7.66	2.72	38.25
		20	-	-	-	-	10.95	5.26	3.15	49.13	10.88	6.07	3.13	48.65	10.80	6.87	3.10	48.00	10.73	7.66	3.08	47.46
	4	15	3.91	3.91	0.84	4.19	4.71	4.71	1.01	6.76	5.53	5.53	1.19	9.29	6.35	6.35	1.37	11.80	7.15	7.15	1.54	14.43
		17	5.86	3.91	1.26	10.26	5.80	4.73	1.25	10.09	5.74	5.54	1.24	9.91	6.36	6.36	1.37	11.83	7.16	7.16	1.55	14.47
		19	-	-	-	-	8.43	4.76	1.81	18.94	8.36	5.57	1.80	18.70	8.30	6.38	1.79	18.48	8.23	7.17	1.77	18.20
		20	-	-	-	-	9.80	4.77	2.11	24.54	9.73	5.59	2.09	24.25	9.67	6.39	2.08	23.96	9.60	7.19	2.06	23.69
	5	15	3.54	3.54	0.61	1.88	4.30	4.30	0.74	2.96	5.05	5.05	0.87	4.61	5.83	5.83	1.00	6.63	6.64	6.64	1.14	8.59
		17	4.70	3.45	0.81	3.79	4.65	4.27	0.80	3.69	5.06	5.06	0.87	4.63	5.84	5.84	1.00	6.65	6.65	6.65	1.14	8.62
		19	-	-	-	-	7.18	4.26	1.24	9.83	7.13	5.07	1.23	9.70	7.07	5.55	1.27	45.00	6.98	6.67	1.20	9.37
		20	-	-	-	-	8.58	4.28	1.48	13.29	8.52	5.09	1.47	13.13	8.46	5.90	1.46	12.97	8.40	6.70	1.44	12.80
6	15	3.12	3.12	0.45	1.30	3.91	3.91	0.56	1.65	4.68	4.68	0.67	2.35	5.42	5.42	0.78	3.48	6.17	6.17	0.88	4.88	
	17	3.79	3.09	0.54	1.58	3.95	3.93	0.57	1.67	4.69	4.69	0.67	2.36	5.43	5.43	0.78	3.50	6.18	6.18	0.89	4.91	
	19	-	-	-	-	5.94	3.77	0.85	4.43	5.91	4.60	0.85	4.40	5.85	5.41	0.84	4.29	6.19	6.17	0.89	4.92	
	20	-	-	-	-	7.25	3.76	1.04	7.17	7.19	4.58	1.03	7.05	7.13	5.38	1.02	6.93	7.06	6.18	1.01	6.77	
9	3	15	3.56	3.56	1.02	6.96	4.40	4.40	1.26	10.13	5.22	5.22	1.50	13.53	6.02	6.02	1.73	17.34	6.82	6.82	1.96	21.39
		17	5.07	3.59	1.45	12.88	5.00	4.41	1.44	12.59	5.21	5.16	1.49	13.49	6.03	6.03	1.73	17.34	6.83	6.83	1.96	21.46
		19	-	-	-	-	7.62	4.43	2.19	25.90	7.57	5.25	2.17	25.57	7.51	6.05	2.16	25.22	7.43	6.85	2.13	24.77
		20	-	-	-	-	8.98	4.44	2.58	34.39	8.92	5.25	2.56	33.98	8.86	6.06	2.55	33.57	8.80	6.86	2.53	33.16
	4	15	3.15	3.15	0.68	2.45	3.92	3.92	0.85	4.42	4.71	4.71	1.01	6.84	5.53	5.53	1.19	9.12	6.34	6.34	1.36	11.50
		17	3.81	3.10	0.82	4.11	3.90	3.86	0.84	4.38	4.72	4.72	1.02	6.86	5.54	5.54	1.19	9.15	6.35	6.35	1.37	11.53
		19	-	-	-	-	6.38	3.94	1.37	11.62	6.32	4.76	1.36	11.44	6.25	5.56	1.34	11.21	6.34	6.30	1.36	11.49
		20	-	-	-	-	7.77	3.96	1.67	16.26	7.71	4.78	1.66	16.06	7.65	5.58	1.65	15.85	7.58	6.38	1.63	15.58
	5	15	2.75	2.75	0.47	1.31	3.54	3.54	0.61	1.87	4.29	4.29	0.74	3.08	5.05	5.05	0.87	4.79	5.84	5.84	1.01	6.73
		17	2.90	2.74	0.50	1.39	3.54	3.54	0.61	1.87	4.29	4.29	0.74	3.09	5.06	5.06	0.87	4.81	5.86	5.86	1.01	6.76
		19	-	-	-	-	5.04	3.44	0.87	4.78	4.98	4.26	0.86	4.63	5.06	5.03	0.87	4.80	5.87	5.87	1.01	6.78
		20	-	-	-	-	6.43	3.45	1.11	8.03	6.38	4.27	1.10	7.91	6.31	5.08	1.09	7.75	6.24	5.88	1.07	7.61
6	15	2.34	2.34	0.34	0.92	3.13	3.13	0.45	1.23	3.91	3.91	0.56	1.60	4.67	4.67	0.67	2.40	5.41	5.41	0.78	3.58	
	17	2.34	2.32	0.34	0.92	3.13	3.13	0.45	1.23	3.92	3.92	0.56	1.61	4.68	4.68	0.67	2.41	5.42	5.42	0.78	3.60	
	19	-	-	-	-	4.08	3.09	0.59	1.73	4.10	3.92	0.59	1.75	4.68	4.68	0.67	2.42	5.43	5.43	0.78	3.62	
	20	-	-	-	-	5.21	3.00	0.75	3.24	5.16	3.83	0.74	3.15	5.12	4.65	0.73	3.08	5.43	5.40	0.78	3.61	

Continue:

MDVF-1200C4E																							
EWT	ΔT	Indoor temp (W.B.)	Indoor temperature (D.B.)																				
			21				23				25				27				29				
			TC	SC	WF	WPD	TC	SC	WF	WPD	TC	SC	WF	WPD	TC	SC	WF	WPD	TC	SC	WF	WPD	
°C	°C	°C	kW	kW	m ³ /h	kPa	kW	kW	m ³ /h	kPa	kW	kW	m ³ /h	kPa	kW	kW	m ³ /h	kPa	kW	kW	m ³ /h	kPa	
11	3	15	2.76	2.76	0.79	3.70	3.57	3.57	1.02	6.89	4.40	4.40	1.25	9.85	5.21	5.21	1.49	13.15	6.02	6.02	1.72	16.80	
		17	2.90	2.75	0.83	4.25	3.58	3.58	1.02	6.91	4.41	4.41	1.26	9.88	5.22	5.22	1.49	13.19	6.03	6.03	1.72	16.85	
		19	-	-	-	-	5.52	3.61	1.58	14.56	5.45	4.43	1.56	14.31	5.42	5.24	1.55	14.16	6.04	6.04	1.72	16.90	
		20	-	-	-	-	6.88	3.62	1.96	21.14	6.82	4.44	1.95	20.86	6.76	5.25	1.93	20.53	6.69	6.05	1.91	20.14	
	4	15	2.37	2.37	0.51	1.37	3.14	3.14	0.67	2.47	3.91	3.91	0.84	4.45	4.72	4.72	1.01	6.79	5.54	5.54	1.19	8.92	
		17	2.37	2.35	0.51	1.37	3.15	3.15	0.67	2.48	3.92	3.92	0.84	4.47	4.73	4.73	1.01	6.81	5.55	5.55	1.19	8.94	
		19	-	-	-	-	4.10	3.10	0.88	5.01	4.08	3.92	0.87	4.94	4.74	4.74	1.01	6.83	5.56	5.56	1.19	8.97	
		20	-	-	-	-	5.54	3.12	1.19	8.93	5.48	3.94	1.17	8.76	5.41	4.76	1.16	8.57	5.54	5.49	1.19	8.92	
	5	15	1.97	1.97	0.34	0.89	2.76	2.76	0.48	1.25	3.54	3.54	0.61	1.91	4.29	4.29	0.74	3.21	5.06	5.06	0.87	4.95	
		17	1.97	1.97	0.34	0.89	2.76	2.76	0.48	1.26	3.55	3.55	0.61	1.92	4.29	4.29	0.74	3.23	5.07	5.07	0.87	4.97	
		19	-	-	-	-	3.13	2.75	0.54	1.47	3.55	3.52	0.61	1.92	4.30	4.30	0.74	3.24	5.08	5.08	0.87	4.99	
		20	-	-	-	-	4.24	2.67	0.73	3.12	4.19	3.49	0.72	3.02	4.31	4.29	0.74	3.26	5.08	5.08	0.88	5.00	
	6	15	1.56	1.56	0.22	0.58	2.35	2.35	0.34	0.87	3.14	3.14	0.45	1.17	3.92	3.92	0.56	1.60	4.66	4.66	0.67	2.49	
		17	1.56	1.56	0.22	0.58	2.36	2.36	0.34	0.87	3.14	3.14	0.45	1.17	3.93	3.93	0.56	1.60	4.67	4.67	0.67	2.50	
		19	-	-	-	-	2.38	2.37	0.34	0.88	3.15	3.15	0.45	1.17	3.93	3.93	0.56	1.61	4.68	4.68	0.67	2.51	
		20	-	-	-	-	3.19	2.31	0.46	1.18	3.28	3.15	0.47	1.22	3.94	3.93	0.56	1.61	4.68	4.68	0.67	2.52	
	13	3	15	1.99	1.99	0.57	1.65	2.76	2.76	0.79	3.94	3.58	3.58	1.03	6.94	4.41	4.41	1.27	9.85	5.21	5.21	1.48	12.92
			17	2.00	2.00	0.57	1.66	2.77	2.77	0.79	3.96	3.59	3.59	1.03	6.96	4.41	4.41	1.27	9.88	5.21	5.21	1.49	12.96
			19	-	-	-	-	3.15	2.76	0.90	5.44	3.59	3.55	1.03	6.95	4.42	4.42	1.27	9.91	5.22	5.22	1.49	13.00
			20	-	-	-	-	4.60	2.79	1.32	10.58	4.53	3.61	1.30	10.31	4.53	4.43	1.30	10.31	5.23	5.23	1.49	13.02
		4	15	1.58	1.58	0.34	0.86	2.38	2.38	0.51	1.34	3.14	3.14	0.68	2.60	3.92	3.92	0.84	4.65	4.73	4.73	1.01	6.71
			17	1.58	1.58	0.34	0.87	2.38	2.38	0.51	1.34	3.15	3.15	0.68	2.61	3.92	3.92	0.85	4.67	4.73	4.73	1.01	6.73
			19	-	-	-	-	2.38	2.35	0.51	1.34	3.15	3.15	0.68	2.62	3.93	3.93	0.85	4.69	4.74	4.74	1.02	6.76
			20	-	-	-	-	3.21	2.32	0.69	2.75	3.24	3.15	0.70	2.82	3.94	3.94	0.85	4.71	4.75	4.75	1.02	6.77
5		15	1.17	1.17	0.20	0.50	1.96	1.96	0.34	0.84	2.76	2.76	0.47	1.19	3.52	3.52	0.60	1.94	4.27	4.27	0.73	3.28	
		17	1.17	1.17	0.20	0.50	1.97	1.97	0.34	0.84	2.76	2.76	0.47	1.19	3.53	3.53	0.61	1.95	4.28	4.28	0.73	3.29	
		19	-	-	-	-	1.97	1.97	0.34	0.84	2.77	2.77	0.47	1.19	3.54	3.54	0.61	1.96	4.29	4.29	0.74	3.31	
		20	-	-	-	-	2.16	1.96	0.37	0.92	2.76	2.74	0.47	1.19	3.54	3.54	0.61	1.96	4.29	4.29	0.74	3.32	
6	15	0.78	0.78	0.11	0.27	1.57	1.57	0.22	0.55	2.35	2.35	0.34	0.83	3.14	3.14	0.45	1.11	3.91	3.91	0.56	1.60		
	17	0.78	0.78	0.11	0.27	1.57	1.57	0.22	0.55	2.36	2.36	0.34	0.83	3.15	3.15	0.45	1.11	3.92	3.92	0.56	1.61		
	19	-	-	-	-	1.57	1.57	0.22	0.55	2.36	2.36	0.34	0.83	3.15	3.15	0.45	1.11	3.93	3.93	0.56	1.62		
	20	-	-	-	-	1.57	1.56	0.23	0.55	2.36	2.36	0.34	0.83	3.15	3.15	0.45	1.11	3.93	3.93	0.56	1.62		
15	3	15	1.19	1.19	0.34	0.83	1.98	1.98	0.57	1.64	2.75	2.75	0.79	3.97	3.58	3.58	1.02	6.74	4.40	4.40	1.25	9.56	
		17	1.19	1.19	0.34	0.83	1.99	1.99	0.57	1.65	2.76	2.76	0.79	3.99	3.59	3.59	1.02	6.76	4.41	4.41	1.26	9.58	
		19	-	-	-	-	1.99	1.99	0.57	1.65	2.76	2.76	0.79	4.01	3.59	3.59	1.03	6.78	4.41	4.41	1.26	9.62	
		20	-	-	-	-	2.17	1.97	0.62	2.10	2.77	2.76	0.79	4.01	3.60	3.60	1.03	6.79	4.42	4.42	1.26	9.63	
	4	15	0.79	0.79	0.17	0.41	1.58	1.58	0.34	0.82	2.38	2.38	0.51	1.31	3.13	3.13	0.67	2.64	3.92	3.92	0.84	4.68	
		17	0.79	0.79	0.17	0.41	1.58	1.58	0.34	0.82	2.38	2.38	0.51	1.31	3.14	3.14	0.67	2.66	3.92	3.92	0.84	4.70	
		19	-	-	-	-	1.59	1.59	0.34	0.82	2.39	2.39	0.51	1.31	3.14	3.14	0.67	2.67	3.93	3.93	0.84	4.72	
		20	-	-	-	-	1.58	1.55	0.34	0.82	2.39	2.39	0.51	1.32	3.15	3.15	0.67	2.68	3.94	3.94	0.84	4.73	
	5	15	0.40	0.40	0.07	0.16	1.19	1.19	0.20	0.48	1.98	1.98	0.34	0.81	2.77	2.77	0.48	1.16	3.52	3.52	0.61	2.04	
		17	0.40	0.40	0.07	0.16	1.19	1.19	0.20	0.48	1.98	1.98	0.34	0.81	2.77	2.77	0.48	1.17	3.53	3.53	0.61	2.04	
		19	-	-	-	-	1.19	1.19	0.21	0.49	1.98	1.98	0.34	0.81	2.78	2.78	0.48	1.17	3.54	3.54	0.61	2.05	
		20	-	-	-	-	1.19	1.19	0.21	0.49	1.99	1.99	0.34	0.81	2.78	2.78	0.48	1.17	3.54	3.54	0.61	2.06	
6	15	-	-	-	-	0.79	0.79	0.11	0.26	1.58	1.58	0.23	0.53	2.36	2.36	0.34	0.79	3.15	3.15	0.45	1.07		
	17	-	-	-	-	0.79	0.79	0.11	0.26	1.58	1.58	0.23	0.53	2.37	2.37	0.34	0.79	3.15	3.15	0.45	1.07		
	19	-	-	-	-	0.79	0.79	0.11	0.26	1.58	1.58	0.23	0.53	2.37	2.37	0.34	0.80	3.16	3.16	0.45	1.08		
	20	-	-	-	-	0.79	0.79	0.11	0.26	1.58	1.58	0.23	0.53	2.37	2.37	0.34	0.80	3.16	3.16	0.45	1.08		

Cooling Capacity

MDVF-1500C4E																						
EWT	ΔT	Indoor temp (W.B.)	Indoor temperature (D.B.)																			
			21				23				25				27				29			
°C	°C	°C	TC	SC	WF	WPD	TC	SC	WF	WPD	TC	SC	WF	WPD	TC	SC	WF	WPD	TC	SC	WF	WPD
			kW	kW	m ³ /h	kPa	kW	kW	m ³ /h	kPa	kW	kW	m ³ /h	kPa	kW	kW	m ³ /h	kPa	kW	kW	m ³ /h	kPa
5	3	15	8.69	6.86	2.48	17.29	8.60	7.87	2.45	16.98	8.86	8.85	2.53	17.88	9.86	9.86	2.84	21.74	10.83	10.83	3.12	25.51
		17	11.76	6.89	3.36	29.05	11.65	7.90	3.33	28.60	11.55	8.90	3.30	28.14	11.44	9.88	3.27	27.68	11.33	10.84	3.24	27.24
		19	-	-	-	-	14.93	7.93	4.27	43.84	14.80	8.93	4.24	43.21	14.68	9.92	4.20	42.59	14.56	10.89	4.16	41.97
		20	-	-	-	-	16.65	7.95	4.77	53.00	16.53	8.96	4.73	52.24	16.38	9.93	4.69	51.51	16.25	10.91	4.66	50.85
	4	15	7.43	6.28	1.60	7.80	7.37	7.30	1.59	7.67	8.30	8.30	1.79	9.84	9.29	9.29	1.99	11.82	10.27	10.27	2.20	14.01
		17	10.51	6.32	2.25	14.59	10.41	7.33	2.23	14.35	10.31	8.33	2.21	14.11	10.21	9.32	2.19	13.88	10.26	10.16	2.20	13.99
		19	-	-	-	-	13.69	7.36	2.93	22.88	13.57	8.37	2.91	22.55	13.47	9.36	2.90	22.43	13.36	10.34	2.88	22.15
		20	-	-	-	-	15.42	7.38	3.31	28.08	15.30	8.39	3.28	27.68	15.17	9.38	3.25	27.29	15.04	10.35	3.23	26.90
	5	15	6.28	5.77	1.08	2.79	6.78	6.78	1.16	3.43	7.75	7.75	1.33	4.95	8.72	8.72	1.50	6.70	9.70	9.70	1.66	8.54
		17	9.18	5.73	1.57	7.57	9.09	6.75	1.56	7.39	8.99	7.75	1.54	7.22	8.92	8.74	1.53	7.07	9.72	9.72	1.67	8.59
		19	-	-	-	-	12.41	6.80	2.13	13.17	12.30	7.80	2.11	12.97	12.19	8.80	2.09	12.77	12.07	9.77	2.07	12.57
		20	-	-	-	-	14.18	6.83	2.44	16.64	14.06	7.84	2.42	16.40	13.94	8.83	2.40	16.16	13.82	9.81	2.38	15.92
6	15	5.24	5.16	0.75	1.58	6.27	6.27	0.90	1.92	7.26	7.26	1.04	2.56	8.22	8.22	1.18	3.58	9.18	9.18	1.31	4.84	
	17	7.98	5.22	1.14	3.30	7.90	6.25	1.13	3.21	7.84	7.26	1.12	3.14	8.24	8.24	1.18	3.60	9.20	9.20	1.32	4.87	
	19	-	-	-	-	11.06	6.22	1.58	7.72	10.96	7.23	1.57	7.56	10.85	8.23	1.55	7.39	10.75	9.21	1.54	7.23	
	20	-	-	-	-	12.82	6.24	1.84	10.19	12.71	7.26	1.82	10.03	12.59	8.25	1.80	9.88	12.48	9.24	1.79	9.72	
7	3	15	6.32	5.80	1.81	9.97	6.82	6.82	1.95	11.33	7.83	7.83	2.24	14.33	8.83	8.83	2.55	17.80	9.79	9.79	2.81	20.99
		17	9.43	5.84	2.72	19.91	9.33	6.86	2.70	19.57	9.24	7.86	2.67	19.24	9.16	8.85	2.65	18.96	9.82	9.82	2.81	21.08
		19	-	-	-	-	12.62	6.89	3.65	32.88	12.51	7.89	3.62	32.37	12.40	8.89	3.58	31.87	12.28	9.87	3.55	31.38
		20	-	-	-	-	14.34	6.90	4.14	40.87	14.22	7.91	4.11	40.43	14.11	8.90	4.08	39.85	13.98	9.88	4.04	39.24
	4	15	5.22	5.10	1.12	3.18	6.26	6.26	1.35	5.24	7.26	7.26	1.56	7.55	8.27	8.27	1.78	9.62	9.25	9.25	2.00	11.71
		17	8.06	5.25	1.74	9.23	7.98	6.28	1.72	9.05	7.89	7.28	1.70	8.89	8.28	8.28	1.78	9.66	9.28	9.28	2.00	11.76
		19	-	-	-	-	11.30	6.32	2.44	16.44	11.19	7.33	2.42	16.18	11.09	8.33	2.40	15.92	10.98	9.31	2.37	15.66
		20	-	-	-	-	13.02	6.33	2.80	20.76	12.91	7.34	2.78	20.45	12.79	8.34	2.75	20.13	12.67	9.32	2.72	19.81
	5	15	4.75	4.75	0.82	1.67	5.76	5.76	0.99	2.33	6.74	6.74	1.16	3.52	7.71	7.71	1.33	5.08	8.69	8.69	1.49	6.83
		17	6.75	4.71	1.16	3.54	6.68	5.74	1.15	3.45	6.72	6.62	1.15	3.50	7.73	7.73	1.33	5.11	8.71	8.71	1.50	6.87
		19	-	-	-	-	9.90	5.74	1.70	8.85	9.80	6.75	1.68	8.69	9.68	7.47	1.74	40.00	9.60	8.74	1.65	8.39
		20	-	-	-	-	11.66	5.76	2.00	11.69	11.55	6.78	1.99	11.50	11.44	7.78	1.97	11.32	11.33	8.77	1.95	11.14
6	15	4.22	4.22	0.61	1.20	5.24	5.24	0.75	1.50	6.24	6.24	0.90	1.89	7.22	7.22	1.04	2.65	8.17	8.17	1.18	3.73	
	17	5.51	4.21	0.79	1.58	5.49	5.25	0.79	1.57	6.25	6.25	0.90	1.90	7.23	7.23	1.04	2.67	8.19	8.19	1.18	3.75	
	19	-	-	-	-	8.53	5.19	1.23	4.18	8.44	6.22	1.21	4.07	8.36	7.22	1.20	3.97	8.32	8.21	1.20	3.91	
	20	-	-	-	-	10.20	5.18	1.46	6.54	10.10	6.20	1.45	6.39	10.00	7.21	1.43	6.24	9.90	8.20	1.42	6.10	
9	3	15	4.74	4.74	1.36	5.47	5.77	5.77	1.65	8.40	6.79	6.79	1.95	11.07	7.79	7.79	2.23	13.99	8.77	8.77	2.53	17.25
		17	6.87	4.76	1.97	11.31	6.80	5.79	1.95	11.11	6.79	6.75	1.95	11.07	7.80	7.80	2.24	14.04	8.79	8.79	2.53	17.32
		19	-	-	-	-	10.09	5.82	2.90	21.78	9.99	6.83	2.87	21.41	9.89	7.83	2.84	21.05	9.80	8.82	2.81	20.71
		20	-	-	-	-	11.86	5.85	3.43	29.12	11.75	6.86	3.40	28.65	11.64	7.86	3.37	28.19	11.53	8.85	3.34	27.75
	4	15	4.23	4.23	0.91	1.95	5.23	5.23	1.13	3.39	6.22	6.22	1.34	5.31	7.22	7.22	1.55	7.46	8.22	8.22	1.77	9.35
		17	5.48	4.20	1.18	3.85	5.44	5.23	1.18	3.78	6.23	6.23	1.34	5.34	7.24	7.24	1.56	7.50	8.24	8.24	1.77	9.38
		19	-	-	-	-	8.67	5.25	1.87	10.24	8.58	6.27	1.85	10.05	8.49	7.27	1.83	9.88	8.43	8.26	1.81	9.76
		20	-	-	-	-	10.44	5.28	2.25	14.10	10.35	6.30	2.24	13.92	10.26	7.31	2.22	13.73	10.16	8.30	2.20	13.51
	5	15	3.70	3.70	0.64	1.22	4.72	4.72	0.81	1.58	5.72	5.72	0.98	2.36	6.69	6.69	1.15	3.62	7.67	7.67	1.32	5.19
		17	4.20	3.70	0.72	1.38	4.73	4.70	0.81	1.59	5.73	5.73	0.99	2.37	6.71	6.71	1.15	3.64	7.69	7.69	1.32	5.22
		19	-	-	-	-	7.21	4.69	1.24	4.43	7.14	5.71	1.23	4.31	7.08	6.72	1.22	4.22	7.71	7.71	1.33	5.26
		20	-	-	-	-	8.94	4.70	1.54	7.30	8.85	5.72	1.52	7.16	8.75	6.73	1.51	7.01	8.67	7.72	1.49	6.87
6	15	3.17	3.17	0.45	0.85	4.20	4.20	0.60	1.13	5.21	5.21	0.75	1.41	6.20	6.20	0.89	1.86	7.17	7.17	1.03	2.69	
	17	3.17	3.10	0.46	0.85	4.21	4.21	0.60	1.13	5.22	5.22	0.75	1.41	6.22	6.22	0.89	1.87	7.19	7.19	1.03	2.71	
	19	-	-	-	-	5.90	4.20	0.85	1.68	5.86	5.23	0.84	1.66	6.22	6.13	0.89	1.87	7.20	7.20	1.03	2.73	
	20	-	-	-	-	7.51	4.17	1.08	3.07	7.44	5.20	1.07	2.98	7.37	6.21	1.06	2.91	7.35	7.22	1.05	2.88	

Continue:

MDVF-1500C4E																						
EWT	ΔT	Indoor temp (W.B.)	Indoor temperature (D.B.)																			
			21				23				25				27				29			
			TC	SC	WF	WPD	TC	SC	WF	WPD	TC	SC	WF	WPD	TC	SC	WF	WPD	TC	SC	WF	WPD
°C	°C	°C	kW	kW	m³/h	kPa	kW	kW	m³/h	kPa	kW	kW	m³/h	kPa	kW	kW	m³/h	kPa	kW	kW	m³/h	kPa
11	3	15	3.69	3.69	1.05	2.85	4.71	4.71	1.34	5.45	5.74	5.74	1.63	8.10	6.75	6.75	1.92	10.66	7.74	7.74	2.21	13.47
		17	4.16	3.69	1.19	3.97	4.72	4.72	1.34	5.48	5.75	5.75	1.64	8.13	6.76	6.76	1.93	10.71	7.76	7.76	2.21	13.53
		19	-	-	-	-	7.39	4.75	2.11	12.44	7.31	5.78	2.08	12.21	7.24	6.78	2.06	12.03	7.78	7.78	2.22	13.59
		20	-	-	-	-	9.14	4.77	2.61	17.89	9.04	5.79	2.58	17.56	8.95	6.80	2.55	17.26	8.86	7.80	2.53	16.98
	4	15	3.17	3.17	0.68	1.26	4.20	4.20	0.90	1.90	5.19	5.19	1.11	3.37	6.19	6.19	1.33	5.33	7.19	7.19	1.54	7.27
		17	3.14	3.02	0.67	1.25	4.21	4.21	0.90	1.92	5.21	5.21	1.11	3.39	6.20	6.20	1.33	5.36	7.21	7.21	1.54	7.30
		19	-	-	-	-	5.86	4.18	1.25	4.66	5.81	5.21	1.24	4.55	6.20	6.15	1.33	5.37	7.23	7.23	1.55	7.33
		20	-	-	-	-	7.61	4.20	1.63	8.01	7.53	5.23	1.61	7.86	7.45	6.24	1.60	7.72	7.40	7.24	1.58	7.64
	5	15	2.65	2.65	0.46	0.83	3.68	3.68	0.63	1.15	4.70	4.70	0.81	1.54	5.69	5.69	0.98	2.42	6.66	6.66	1.15	3.72
		17	2.66	2.66	0.46	0.83	3.69	3.69	0.64	1.15	4.71	4.71	0.81	1.54	5.70	5.70	0.98	2.43	6.68	6.68	1.15	3.74
		19	-	-	-	-	4.52	3.69	0.78	1.44	4.70	4.60	0.81	1.54	5.71	5.71	0.98	2.45	6.69	6.69	1.15	3.77
		20	-	-	-	-	6.12	3.66	1.05	2.95	6.06	4.70	1.04	2.88	6.03	5.71	1.04	2.83	6.70	6.70	1.15	3.78
6	15	2.13	2.13	0.31	0.54	3.16	3.16	0.45	0.81	4.18	4.18	0.60	1.07	5.19	5.19	0.74	1.34	6.17	6.17	0.89	1.87	
	17	2.13	2.13	0.31	0.54	3.17	3.17	0.45	0.81	4.19	4.19	0.60	1.07	5.20	5.20	0.75	1.35	6.18	6.18	0.89	1.89	
	19	-	-	-	-	3.24	3.23	0.46	0.83	4.20	4.20	0.60	1.07	5.21	5.21	0.75	1.35	6.20	6.20	0.89	1.90	
	20	-	-	-	-	4.69	3.16	0.67	1.20	4.68	4.20	0.67	1.19	5.21	5.15	0.75	1.35	6.21	6.21	0.89	1.90	
13	3	15	2.65	2.65	0.76	1.39	3.67	3.67	1.05	2.99	4.69	4.69	1.35	5.59	5.71	5.71	1.64	8.01	6.71	6.71	1.93	10.54
		17	2.66	2.66	0.76	1.39	3.68	3.68	1.06	3.01	4.70	4.70	1.35	5.62	5.72	5.72	1.64	8.04	6.73	6.73	1.93	10.58
		19	-	-	-	-	4.48	3.68	1.29	5.03	4.65	4.47	1.34	5.50	5.74	5.74	1.65	8.08	6.74	6.74	1.94	10.63
		20	-	-	-	-	6.23	3.70	1.79	9.28	6.16	4.73	1.77	9.10	6.11	5.75	1.76	8.99	6.75	6.75	1.94	10.65
	4	15	2.13	2.13	0.46	0.80	3.16	3.16	0.68	1.20	4.17	4.17	0.90	1.96	5.17	5.17	1.11	3.51	6.15	6.15	1.32	5.35
		17	2.13	2.13	0.46	0.80	3.17	3.17	0.68	1.20	4.18	4.18	0.90	1.97	5.18	5.18	1.11	3.53	6.16	6.16	1.32	5.38
		19	-	-	-	-	3.19	3.14	0.69	1.21	4.19	4.19	0.90	1.99	5.19	5.19	1.12	3.55	6.18	6.18	1.32	5.41
		20	-	-	-	-	4.66	3.15	1.00	2.64	4.63	4.19	1.00	2.60	5.20	5.17	1.12	3.56	6.19	6.19	1.33	5.43
	5	15	1.60	1.60	0.27	0.47	2.64	2.64	0.45	0.78	3.66	3.66	0.63	1.08	4.67	4.67	0.80	1.50	5.65	5.65	0.97	2.44
		17	1.60	1.60	0.27	0.47	2.64	2.64	0.45	0.78	3.67	3.67	0.63	1.08	4.68	4.68	0.80	1.51	5.66	5.66	0.97	2.46
		19	-	-	-	-	2.65	2.64	0.45	0.78	3.68	3.68	0.63	1.09	4.69	4.69	0.80	1.51	5.67	5.67	0.97	2.47
		20	-	-	-	-	3.19	2.64	0.55	0.94	3.67	3.59	0.63	1.09	4.70	4.70	0.81	1.52	5.68	5.68	0.97	2.48
6	15	1.08	1.08	0.15	0.26	2.12	2.12	0.30	0.51	3.15	3.15	0.45	0.76	4.16	4.16	0.59	1.01	5.16	5.16	0.74	1.29	
	17	1.08	1.08	0.15	0.26	2.12	2.12	0.30	0.51	3.15	3.15	0.45	0.76	4.17	4.17	0.60	1.01	5.17	5.17	0.74	1.29	
	19	-	-	-	-	2.13	2.13	0.30	0.51	3.16	3.16	0.45	0.76	4.18	4.18	0.60	1.01	5.18	5.18	0.74	1.30	
	20	-	-	-	-	2.14	2.08	0.31	0.52	3.17	3.17	0.45	0.76	4.18	4.18	0.60	1.01	5.19	5.19	0.74	1.30	
15	3	15	1.59	1.59	0.45	0.77	2.63	2.63	0.75	1.32	3.64	3.64	1.04	2.99	4.66	4.66	1.33	5.48	5.67	5.67	1.62	7.71
		17	1.60	1.60	0.46	0.77	2.64	2.64	0.75	1.33	3.65	3.65	1.04	3.01	4.67	4.67	1.33	5.50	5.69	5.69	1.62	7.75
		19	-	-	-	-	2.65	2.65	0.75	1.34	3.66	3.66	1.04	3.03	4.68	4.68	1.34	5.53	5.70	5.70	1.63	7.78
		20	-	-	-	-	3.16	2.64	0.90	2.03	3.65	3.57	1.04	3.00	4.69	4.69	1.34	5.55	5.71	5.71	1.63	7.80
	4	15	1.07	1.07	0.23	0.38	2.11	2.11	0.45	0.76	3.14	3.14	0.67	1.13	4.15	4.15	0.89	1.97	5.13	5.13	1.10	3.53
		17	1.07	1.07	0.23	0.38	2.12	2.12	0.45	0.76	3.15	3.15	0.67	1.13	4.16	4.16	0.89	1.99	5.15	5.15	1.10	3.55
		19	-	-	-	-	2.12	2.12	0.46	0.76	3.16	3.16	0.68	1.13	4.17	4.17	0.89	2.00	5.16	5.16	1.11	3.57
		20	-	-	-	-	2.10	1.98	0.45	0.75	3.16	3.16	0.68	1.14	4.17	4.17	0.89	2.01	5.17	5.17	1.11	3.58
	5	15	0.54	0.54	0.09	0.15	1.60	1.60	0.28	0.45	2.63	2.63	0.45	0.74	3.65	3.65	0.63	1.03	4.65	4.65	0.80	1.52
		17	0.55	0.55	0.09	0.15	1.60	1.60	0.28	0.45	2.64	2.64	0.45	0.74	3.66	3.66	0.63	1.03	4.66	4.66	0.80	1.53
		19	-	-	-	-	1.60	1.60	0.28	0.45	2.64	2.64	0.46	0.75	3.66	3.66	0.63	1.03	4.67	4.67	0.80	1.54
		20	-	-	-	-	1.61	1.61	0.28	0.45	2.65	2.65	0.46	0.75	3.67	3.67	0.63	1.04	4.68	4.68	0.81	1.54
6	15	-	-	-	-	1.07	1.07	0.15	0.25	2.11	2.11	0.30	0.49	3.13	3.13	0.45	0.72	4.14	4.14	0.59	0.96	
	17	-	-	-	-	1.08	1.08	0.15	0.25	2.12	2.12	0.30	0.49	3.14	3.14	0.45	0.72	4.15	4.15	0.60	0.96	
	19	-	-	-	-	1.08	1.08	0.15	0.25	2.12	2.12	0.30	0.49	3.15	3.15	0.45	0.73	4.16	4.16	0.60	0.96	
	20	-	-	-	-	1.08	1.08	0.16	0.25	2.12	2.12	0.31	0.49	3.15	3.15	0.45	0.73	4.17	4.17	0.60	0.96	

Compact four-way cassette:

MDVF-300C4CE																							
EWT	ΔT	Indoor temp (W.B.)	Indoor temperature (D.B.)																				
			21				23				25				27				29				
			TC	SC	WF	WPD	TC	SC	WF	WPD	TC	SC	WF	WPD	TC	SC	WF	WPD	TC	SC	WF	WPD	
°C	°C	°C	kW	kW	m ³ /h	kPa	kW	kW	m ³ /h	kPa	kW	kW	m ³ /h	kPa	kW	kW	m ³ /h	kPa	kW	kW	m ³ /h	kPa	
5	3	15	2.21	1.74	0.63	28.92	2.19	2.00	0.63	28.45	2.26	2.25	0.65	30.05	2.52	2.52	0.72	36.17	2.77	2.77	0.79	42.67	
		17	3.00	1.75	0.86	49.45	2.98	2.01	0.86	48.87	2.96	2.27	0.85	48.31	2.93	2.53	0.85	47.63	2.91	2.78	0.84	47.03	
		19	-	-	-	-	3.81	2.02	1.10	75.06	3.79	2.28	1.09	74.21	3.76	2.54	1.09	73.37	3.74	2.79	1.08	72.55	
		20	-	-	-	-	4.25	2.02	1.23	90.97	4.23	2.28	1.22	89.95	4.20	2.54	1.21	88.65	4.17	2.79	1.20	86.62	
	4	15	1.88	1.59	0.40	13.34	1.88	1.86	0.40	13.35	2.12	2.12	0.46	16.56	2.38	2.38	0.51	20.11	2.63	2.63	0.56	23.66	
		17	2.67	1.60	0.57	24.31	2.65	1.86	0.57	24.01	2.63	2.12	0.56	23.68	2.61	2.38	0.56	23.33	2.64	2.63	0.57	23.79	
		19	-	-	-	-	3.50	1.88	0.75	38.84	3.47	2.13	0.74	38.02	3.44	2.39	0.74	37.58	3.42	2.65	0.73	37.15	
		20	-	-	-	-	3.94	1.88	0.85	47.30	3.91	2.14	0.84	46.77	3.88	2.40	0.83	46.25	3.86	2.65	0.83	45.72	
	5	15	1.58	1.46	0.27	5.13	1.71	1.71	0.29	6.39	1.97	1.97	0.34	9.19	2.23	2.23	0.38	12.07	2.49	2.49	0.43	14.66	
		17	2.33	1.45	0.40	13.14	2.31	1.72	0.40	12.94	2.29	1.98	0.39	12.72	2.29	2.23	0.39	12.67	2.49	2.49	0.43	14.71	
		19	-	-	-	-	3.16	1.73	0.54	22.05	3.14	1.99	0.54	21.78	3.12	2.25	0.53	21.52	3.09	2.50	0.53	21.23	
		20	-	-	-	-	3.61	1.73	0.62	27.62	3.58	1.99	0.62	27.30	3.56	2.25	0.61	26.99	3.54	2.51	0.61	26.68	
6	15	1.37	1.34	0.20	2.50	1.59	1.59	0.23	3.29	1.84	1.84	0.26	4.83	2.09	2.09	0.30	6.82	2.34	2.34	0.34	9.12		
	17	2.01	1.31	0.29	6.10	1.99	1.58	0.28	5.95	1.98	1.84	0.28	5.88	2.10	2.09	0.30	6.85	2.35	2.35	0.34	9.17		
	19	-	-	-	-	2.82	1.58	0.40	13.33	2.80	1.84	0.40	13.16	2.78	2.10	0.40	12.97	2.75	2.36	0.40	12.77		
	20	-	-	-	-	3.27	1.59	0.47	16.98	3.24	1.85	0.46	16.78	3.22	2.11	0.46	16.58	3.20	2.37	0.46	16.54		
7	3	15	1.62	1.48	0.47	16.97	1.74	1.74	0.50	19.21	2.00	2.00	0.57	24.05	2.26	2.26	0.65	30.05	2.51	2.51	0.73	36.11	
		17	2.40	1.48	0.69	33.41	2.38	1.75	0.69	32.97	2.36	2.01	0.68	32.43	2.35	2.26	0.68	32.14	2.52	2.52	0.73	36.24	
		19	-	-	-	-	3.21	1.75	0.92	54.56	3.19	2.01	0.92	53.91	3.17	2.27	0.91	53.26	3.15	2.52	0.90	52.60	
		20	-	-	-	-	3.66	1.76	1.06	68.86	3.64	2.02	1.05	68.06	3.61	2.28	1.04	67.29	3.59	2.53	1.04	66.50	
	4	15	1.33	1.33	0.29	6.18	1.59	1.59	0.34	9.65	1.86	1.86	0.40	13.05	2.12	2.12	0.46	16.30	2.37	2.37	0.51	19.59	
		17	2.06	1.34	0.44	15.55	2.04	1.60	0.44	15.29	2.02	1.86	0.44	15.09	2.12	2.11	0.46	16.33	2.37	2.37	0.51	19.65	
		19	-	-	-	-	2.88	1.61	0.62	27.33	2.86	1.87	0.62	26.99	2.84	2.13	0.61	26.64	2.81	2.38	0.61	26.24	
		20	-	-	-	-	3.33	1.61	0.72	35.38	3.31	1.88	0.72	34.96	3.28	2.13	0.71	34.55	3.26	2.39	0.71	34.13	
	5	15	1.21	1.20	0.21	2.70	1.46	1.46	0.25	4.33	1.71	1.71	0.29	6.68	1.97	1.97	0.34	9.43	2.23	2.23	0.38	11.99	
		17	1.70	1.19	0.29	6.54	1.68	1.45	0.29	6.39	1.73	1.72	0.30	6.85	1.97	1.97	0.34	9.47	2.23	2.23	0.38	12.03	
		19	-	-	-	-	2.53	1.46	0.44	14.91	2.51	1.72	0.43	14.69	2.50	2.04	0.45	15.00	2.46	2.24	0.42	14.25	
		20	-	-	-	-	2.98	1.47	0.51	19.62	2.95	1.73	0.51	19.38	2.93	1.99	0.50	19.14	2.91	2.25	0.50	18.86	
6	15	1.08	1.08	0.15	1.84	1.34	1.34	0.19	2.36	1.59	1.59	0.23	3.42	1.84	1.84	0.26	5.00	2.09	2.09	0.30	7.04		
	17	1.40	1.07	0.20	2.54	1.42	1.34	0.20	2.63	1.59	1.59	0.23	3.43	1.84	1.84	0.26	5.03	2.09	2.09	0.30	7.08		
	19	-	-	-	-	2.15	1.31	0.31	7.65	2.13	1.58	0.31	7.46	2.12	1.84	0.30	7.31	2.14	2.10	0.31	7.51		
	20	-	-	-	-	2.61	1.32	0.37	11.41	2.58	1.58	0.37	11.25	2.56	1.84	0.37	11.07	2.54	2.10	0.36	10.88		
9	3	15	1.20	1.20	0.34	9.87	1.47	1.47	0.42	14.06	1.73	1.73	0.50	18.58	1.99	1.99	0.57	23.60	2.25	2.25	0.65	29.48	
		17	1.75	1.21	0.50	18.93	1.73	1.47	0.50	18.59	1.75	1.74	0.50	18.92	2.00	2.00	0.57	23.68	2.26	2.26	0.65	29.58	
		19	-	-	-	-	2.58	1.48	0.74	36.75	2.56	1.74	0.74	36.27	2.54	2.00	0.73	35.70	2.51	2.26	0.72	35.18	
		20	-	-	-	-	3.03	1.49	0.88	49.13	3.01	1.75	0.87	48.55	2.99	2.01	0.87	47.95	2.96	2.27	0.86	47.29	
	4	15	1.07	1.07	0.23	3.58	1.33	1.33	0.29	6.29	1.59	1.59	0.34	9.67	1.85	1.85	0.40	12.68	2.11	2.11	0.45	15.85	
		17	1.38	1.06	0.30	6.96	1.38	1.33	0.30	7.02	1.59	1.59	0.34	9.71	1.85	1.85	0.40	12.72	2.11	2.11	0.46	15.90	
		19	-	-	-	-	2.22	1.34	0.48	17.34	2.20	1.60	0.47	17.05	2.18	1.86	0.47	16.77	2.18	2.12	0.47	16.82	
		20	-	-	-	-	2.67	1.35	0.58	23.92	2.65	1.61	0.57	23.62	2.63	1.87	0.57	23.27	2.60	2.12	0.56	22.75	
	5	15	0.94	0.94	0.16	1.86	1.20	1.20	0.21	2.71	1.45	1.45	0.25	4.49	1.71	1.71	0.29	6.89	1.97	1.97	0.34	9.48	
		17	1.07	0.94	0.18	2.18	1.21	1.21	0.21	2.75	1.46	1.46	0.25	4.51	1.71	1.71	0.29	6.92	1.97	1.97	0.34	9.52	
		19	-	-	-	-	1.83	1.19	0.32	8.15	1.81	1.45	0.31	7.95	1.81	1.71	0.31	7.94	1.97	1.97	0.34	9.55	
		20	-	-	-	-	2.29	1.20	0.39	12.39	2.27	1.46	0.39	12.19	2.25	1.72	0.39	11.98	2.23	1.98	0.38	11.83	
6	15	0.81	0.81	0.12	1.31	1.07	1.07	0.15	1.74	1.33	1.33	0.19	2.30	1.58	1.58	0.23	3.49	1.83	1.83	0.26	5.19		
	17	0.84	0.82	0.12	1.36	1.08	1.08	0.15	1.74	1.34	1.34	0.19	2.31	1.59	1.59	0.23	3.51	1.84	1.84	0.26	5.22		
	19	-	-	-	-	1.49	1.06	0.21	2.99	1.50	1.33	0.21	3.00	1.61	1.59	0.23	3.64	1.84	1.84	0.26	5.25		
	20	-	-	-	-	1.90	1.05	0.27	5.73	1.88	1.32	0.27	5.58	1.87	1.58	0.27	5.46	1.90	1.84	0.27	5.71		

Continue:

MDVF-300C4CE																							
EWT	ΔT	Indoor temp (W.B.)	Indoor temperature (D.B.)																				
			21				23				25				27				29				
			TC	SC	WF	WPD	TC	SC	WF	WPD	TC	SC	WF	WPD	TC	SC	WF	WPD	TC	SC	WF	WPD	
°C	°C	°C	kW	kW	m ³ /h	kPa	kW	kW	m ³ /h	kPa	kW	kW	m ³ /h	kPa	kW	kW	m ³ /h	kPa	kW	kW	m ³ /h	kPa	
11	3	15	0.94	0.94	0.27	5.39	1.20	1.20	0.34	9.68	1.47	1.47	0.42	13.62	1.73	1.73	0.49	18.02	1.99	1.99	0.57	22.88	
		17	1.05	0.93	0.30	7.34	1.20	1.20	0.34	9.70	1.47	1.47	0.42	13.67	1.73	1.73	0.49	18.08	1.99	1.99	0.57	22.96	
		19	-	-	-	-	1.89	1.21	0.54	21.04	1.87	1.48	0.53	20.66	1.86	1.74	0.53	20.47	1.99	1.99	0.57	23.02	
		20	-	-	-	-	2.34	1.22	0.67	30.29	2.32	1.48	0.66	29.83	2.30	1.74	0.66	29.34	2.28	2.00	0.65	28.90	
	4	15	0.81	0.81	0.17	1.95	1.07	1.07	0.23	3.60	1.32	1.32	0.28	6.41	1.59	1.59	0.34	9.51	1.85	1.85	0.40	12.33	
		17	0.82	0.82	0.18	1.99	1.07	1.07	0.23	3.61	1.33	1.33	0.28	6.44	1.59	1.59	0.34	9.54	1.85	1.85	0.40	12.37	
		19	-	-	-	-	1.49	1.06	0.32	8.46	1.48	1.33	0.32	8.35	1.59	1.58	0.34	9.58	1.85	1.85	0.40	12.42	
		20	-	-	-	-	1.95	1.07	0.42	13.55	1.93	1.34	0.41	13.30	1.91	1.60	0.41	13.08	1.92	1.86	0.41	13.21	
	5	15	0.68	0.68	0.12	1.28	0.94	0.94	0.16	1.77	1.20	1.20	0.21	2.78	1.45	1.45	0.25	4.66	1.71	1.71	0.29	7.06	
		17	0.68	0.68	0.12	1.28	0.95	0.95	0.16	1.78	1.20	1.20	0.21	2.79	1.45	1.45	0.25	4.68	1.71	1.71	0.29	7.09	
		19	-	-	-	-	1.15	0.94	0.20	2.51	1.24	1.21	0.21	3.00	1.46	1.46	0.25	4.71	1.71	1.71	0.30	7.12	
		20	-	-	-	-	1.55	0.93	0.27	5.53	1.53	1.19	0.26	5.39	1.55	1.46	0.27	5.50	1.71	1.71	0.30	7.13	
	6	15	0.55	0.55	0.08	0.84	0.81	0.81	0.12	1.24	1.07	1.07	0.15	1.65	1.33	1.33	0.19	2.30	1.58	1.58	0.23	3.61	
		17	0.55	0.55	0.08	0.84	0.82	0.82	0.12	1.25	1.08	1.08	0.15	1.65	1.33	1.33	0.19	2.31	1.58	1.58	0.23	3.63	
		19	-	-	-	-	0.87	0.82	0.13	1.34	1.08	1.08	0.15	1.66	1.34	1.34	0.19	2.33	1.59	1.59	0.23	3.65	
		20	-	-	-	-	1.20	0.81	0.17	1.88	1.22	1.08	0.17	1.93	1.36	1.34	0.19	2.42	1.59	1.59	0.23	3.66	
	13	3	15	0.68	0.68	0.19	2.39	0.93	0.93	0.27	5.69	1.20	1.20	0.34	9.67	1.46	1.46	0.42	13.35	1.73	1.73	0.50	17.92
			17	0.68	0.68	0.19	2.40	0.94	0.94	0.27	5.71	1.20	1.20	0.35	9.71	1.47	1.47	0.42	13.39	1.73	1.73	0.50	17.98
			19	-	-	-	-	1.15	0.94	0.33	8.92	1.21	1.20	0.35	9.77	1.47	1.47	0.42	13.44	1.73	1.73	0.50	18.04
			20	-	-	-	-	1.60	0.94	0.46	15.76	1.58	1.21	0.45	15.46	1.58	1.47	0.45	15.42	1.73	1.73	0.50	18.05
		4	15	0.55	0.55	0.12	1.23	0.81	0.81	0.17	1.91	1.06	1.06	0.23	3.77	1.32	1.32	0.28	6.53	1.58	1.58	0.34	9.35
			17	0.55	0.55	0.12	1.24	0.81	0.81	0.17	1.92	1.07	1.07	0.23	3.79	1.32	1.32	0.28	6.56	1.59	1.59	0.34	9.38
			19	-	-	-	-	0.85	0.82	0.18	2.07	1.07	1.07	0.23	3.81	1.33	1.33	0.28	6.59	1.59	1.59	0.34	9.42
			20	-	-	-	-	1.18	0.80	0.25	4.95	1.18	1.07	0.25	4.97	1.33	1.32	0.28	6.60	1.59	1.59	0.34	9.43
5		15	0.41	0.41	0.07	0.73	0.68	0.68	0.12	1.20	0.94	0.94	0.16	1.69	1.20	1.20	0.21	2.82	1.45	1.45	0.25	4.73	
		17	0.41	0.41	0.07	0.73	0.68	0.68	0.12	1.20	0.94	0.94	0.16	1.69	1.20	1.20	0.21	2.83	1.45	1.45	0.25	4.76	
		19	-	-	-	-	0.68	0.68	0.12	1.21	0.94	0.94	0.16	1.70	1.20	1.20	0.21	2.85	1.45	1.45	0.25	4.78	
		20	-	-	-	-	0.82	0.68	0.14	1.45	0.97	0.95	0.17	1.75	1.20	1.20	0.21	2.86	1.45	1.45	0.25	4.80	
6	15	0.28	0.28	0.04	0.41	0.55	0.55	0.08	0.79	0.81	0.81	0.12	1.18	1.07	1.07	0.15	1.56	1.33	1.33	0.19	2.32		
	17	0.28	0.28	0.04	0.41	0.55	0.55	0.08	0.80	0.81	0.81	0.12	1.18	1.07	1.07	0.15	1.57	1.33	1.33	0.19	2.33		
	19	-	-	-	-	0.55	0.55	0.08	0.80	0.82	0.82	0.12	1.18	1.08	1.08	0.15	1.57	1.33	1.33	0.19	2.34		
	20	-	-	-	-	0.58	0.56	0.08	0.84	0.82	0.81	0.12	1.18	1.08	1.08	0.15	1.57	1.33	1.33	0.19	2.35		
15	3	15	0.41	0.41	0.12	1.19	0.67	0.67	0.19	2.38	0.93	0.93	0.27	5.70	1.20	1.20	0.34	9.37	1.46	1.46	0.42	13.12	
		17	0.41	0.41	0.12	1.19	0.67	0.67	0.19	2.39	0.93	0.93	0.27	5.72	1.20	1.20	0.34	9.40	1.46	1.46	0.42	13.16	
		19	-	-	-	-	0.68	0.67	0.19	2.40	0.93	0.93	0.27	5.75	1.20	1.20	0.34	9.43	1.47	1.47	0.42	13.21	
		20	-	-	-	-	0.80	0.67	0.23	3.82	0.93	0.92	0.27	5.73	1.20	1.20	0.34	9.45	1.47	1.47	0.42	13.24	
	4	15	0.28	0.28	0.06	0.59	0.54	0.54	0.12	1.16	0.81	0.81	0.17	1.87	1.06	1.06	0.23	3.83	1.32	1.32	0.28	6.62	
		17	0.28	0.28	0.06	0.60	0.55	0.55	0.12	1.17	0.81	0.81	0.17	1.88	1.06	1.06	0.23	3.85	1.32	1.32	0.28	6.65	
		19	-	-	-	-	0.55	0.55	0.12	1.17	0.81	0.81	0.17	1.89	1.07	1.07	0.23	3.87	1.32	1.32	0.28	6.68	
		20	-	-	-	-	0.56	0.56	0.12	1.19	0.81	0.81	0.17	1.89	1.07	1.07	0.23	3.88	1.33	1.33	0.28	6.70	
	5	15	0.14	0.14	0.02	0.24	0.42	0.42	0.07	0.70	0.68	0.68	0.12	1.15	0.94	0.94	0.16	1.66	1.19	1.19	0.21	2.95	
		17	0.15	0.15	0.03	0.24	0.42	0.42	0.07	0.70	0.68	0.68	0.12	1.15	0.94	0.94	0.16	1.66	1.19	1.19	0.21	2.96	
		19	-	-	-	-	0.42	0.42	0.07	0.70	0.68	0.68	0.12	1.15	0.94	0.94	0.16	1.67	1.20	1.20	0.21	2.98	
		20	-	-	-	-	0.42	0.41	0.07	0.70	0.68	0.68	0.12	1.15	0.95	0.95	0.16	1.67	1.20	1.20	0.21	2.99	
6	15	-	-	-	-	0.28	0.28	0.04	0.39	0.55	0.55	0.08	0.76	0.81	0.81	0.12	1.12	1.07	1.07	0.15	1.51		
	17	-	-	-	-	0.28	0.28	0.04	0.39	0.55	0.55	0.08	0.76	0.81	0.81	0.12	1.12	1.07	1.07	0.15	1.52		
	19	-	-	-	-	0.28	0.28	0.04	0.39	0.55	0.55	0.08	0.76	0.81	0.81	0.12	1.13	1.07	1.07	0.15	1.52		
	20	-	-	-	-	0.28	0.28	0.04	0.39	0.55	0.55	0.08	0.76	0.82	0.82	0.12	1.13	1.08	1.08	0.15	1.53		

Cooling Capacity

MDVF-400C4CE																						
EWT	ΔT	Indoor temp (W.B.)	Indoor temperature (D.B.)																			
			21				23				25				27				29			
			TC	SC	WF	WPD	TC	SC	WF	WPD	TC	SC	WF	WPD	TC	SC	WF	WPD	TC	SC	WF	WPD
°C	°C	°C	kW	kW	m³/h	kPa	kW	kW	m³/h	kPa	kW	kW	m³/h	kPa	kW	kW	m³/h	kPa	kW	kW	m³/h	kPa
5	3	15	2.78	2.21	0.80	16.21	2.75	2.55	0.79	15.98	2.88	2.88	0.82	17.04	3.22	3.22	0.93	20.83	3.55	3.55	1.02	24.60
		17	3.78	2.22	1.08	27.13	3.76	2.56	1.08	27.03	3.73	2.89	1.07	26.72	3.71	3.22	1.06	26.47	3.68	3.55	1.06	26.21
		19	-	-	-	-	4.84	2.57	1.39	41.79	4.81	2.91	1.38	41.33	4.78	3.24	1.37	40.87	4.75	3.56	1.36	40.32
		20	-	-	-	-	5.41	2.58	1.56	50.89	5.38	2.91	1.55	50.50	5.35	3.24	1.54	49.96	5.31	3.57	1.53	49.42
	4	15	2.32	2.01	0.50	6.62	2.34	2.32	0.50	6.71	2.68	2.68	0.58	9.21	3.01	3.01	0.65	11.24	3.35	3.35	0.72	13.42
		17	3.34	2.02	0.72	13.37	3.31	2.36	0.71	13.21	3.29	2.69	0.70	13.03	3.26	3.02	0.70	12.82	3.35	3.34	0.72	13.45
		19	-	-	-	-	4.41	2.37	0.95	21.65	4.38	2.71	0.94	21.41	4.35	3.04	0.94	21.17	4.32	3.37	0.93	20.93
		20	-	-	-	-	4.97	2.38	1.07	26.36	4.94	2.71	1.06	26.07	4.91	3.04	1.05	25.78	4.88	3.37	1.05	25.50
	5	15	1.97	1.85	0.34	2.39	2.18	2.18	0.37	3.07	2.50	2.50	0.43	4.45	2.82	2.82	0.48	6.11	3.14	3.14	0.54	7.98
		17	2.87	1.81	0.49	6.41	2.85	2.15	0.49	6.29	2.82	2.49	0.48	6.14	2.82	2.82	0.48	6.14	3.15	3.15	0.54	8.02
		19	-	-	-	-	3.94	2.17	0.68	12.08	3.92	2.51	0.67	11.94	3.89	2.84	0.67	11.80	3.86	3.17	0.66	11.65
		20	-	-	-	-	4.53	2.18	0.78	15.42	4.50	2.52	0.78	15.25	4.47	2.85	0.77	15.07	4.43	3.18	0.76	14.74
6	15	1.69	1.68	0.24	1.53	2.01	2.01	0.29	1.83	2.34	2.34	0.33	2.35	2.66	2.66	0.38	3.24	2.97	2.97	0.43	4.40	
	17	2.50	1.66	0.36	2.76	2.48	2.00	0.35	2.69	2.47	2.34	0.35	2.66	2.66	2.66	0.38	3.25	2.98	2.98	0.43	4.42	
	19	-	-	-	-	3.46	1.97	0.50	6.60	3.44	2.31	0.49	6.49	3.42	2.64	0.49	6.37	3.39	2.97	0.48	6.24	
	20	-	-	-	-	4.04	1.97	0.58	9.18	4.01	2.31	0.57	9.06	3.98	2.65	0.57	8.95	3.96	2.98	0.57	8.83	
7	3	15	1.99	1.86	0.57	8.93	2.20	2.20	0.63	10.69	2.54	2.54	0.73	13.63	2.88	2.88	0.83	17.07	3.21	3.21	0.93	20.54
		17	3.02	1.88	0.87	18.53	3.00	2.22	0.87	18.29	2.97	2.55	0.86	18.00	2.95	2.89	0.85	17.78	3.22	3.22	0.93	20.61
		19	-	-	-	-	4.08	2.23	1.18	31.00	4.05	2.57	1.17	30.64	4.03	2.90	1.16	30.29	4.00	3.23	1.16	29.92
		20	-	-	-	-	4.65	2.23	1.34	38.83	4.62	2.57	1.34	38.38	4.59	2.90	1.33	37.96	4.56	3.23	1.32	37.53
	4	15	1.68	1.67	0.36	2.87	2.01	2.01	0.43	4.69	2.34	2.34	0.50	6.95	2.68	2.68	0.58	9.13	3.01	3.01	0.65	11.15
		17	2.54	1.67	0.55	8.25	2.51	2.01	0.54	8.08	2.48	2.35	0.54	7.91	2.69	2.69	0.58	9.17	3.02	3.02	0.65	11.19
		19	-	-	-	-	3.62	2.03	0.78	15.27	3.59	2.37	0.78	15.09	3.57	2.70	0.77	14.90	3.53	3.03	0.76	14.68
		20	-	-	-	-	4.18	2.03	0.90	19.39	4.15	2.37	0.89	19.17	4.13	2.71	0.89	18.94	4.10	3.04	0.88	18.72
	5	15	1.52	1.52	0.26	1.60	1.85	1.85	0.32	2.13	2.17	2.17	0.37	3.18	2.49	2.49	0.43	4.62	2.82	2.82	0.48	6.34
		17	2.11	1.50	0.36	2.94	2.09	1.84	0.36	2.87	2.17	2.16	0.37	3.18	2.50	2.50	0.43	4.65	2.82	2.82	0.49	6.37
		19	-	-	-	-	3.11	1.82	0.54	7.91	3.09	2.16	0.53	7.79	3.09	2.49	0.56	15.00	3.03	2.83	0.52	7.49
		20	-	-	-	-	3.70	1.83	0.64	10.71	3.67	2.17	0.63	10.58	3.65	2.51	0.63	10.45	3.62	2.84	0.62	10.31
6	15	1.35	1.35	0.19	1.16	1.68	1.68	0.24	1.45	2.01	2.01	0.29	1.78	2.34	2.34	0.34	2.43	2.65	2.65	0.38	3.41	
	17	1.71	1.34	0.25	1.46	1.74	1.69	0.25	1.49	2.02	2.02	0.29	1.79	2.34	2.34	0.34	2.44	2.66	2.66	0.38	3.42	
	19	-	-	-	-	2.67	1.65	0.38	3.49	2.65	1.99	0.38	3.40	2.63	2.33	0.38	3.33	2.67	2.66	0.38	3.46	
	20	-	-	-	-	3.19	1.63	0.46	5.55	3.17	1.97	0.45	5.45	3.14	2.31	0.45	5.33	3.11	2.65	0.45	5.21	
9	3	15	1.52	1.52	0.44	4.90	1.86	1.86	0.53	7.87	2.20	2.20	0.63	10.53	2.54	2.54	0.73	13.40	2.87	2.87	0.83	16.64
		17	2.18	1.53	0.63	10.36	2.16	1.87	0.62	10.15	2.19	2.17	0.63	10.46	2.54	2.54	0.73	13.44	2.88	2.88	0.83	16.69
		19	-	-	-	-	3.25	1.88	0.93	20.43	3.23	2.22	0.93	20.17	3.20	2.55	0.92	19.87	3.17	2.88	0.91	19.55
		20	-	-	-	-	3.83	1.89	1.11	27.45	3.81	2.23	1.10	27.12	3.78	2.56	1.09	26.79	3.74	2.89	1.07	26.01
	4	15	1.36	1.36	0.29	1.81	1.68	1.68	0.36	3.05	2.01	2.01	0.43	4.83	2.34	2.34	0.50	7.00	2.68	2.68	0.58	8.95
		17	1.71	1.34	0.37	3.19	1.72	1.69	0.37	3.22	2.01	2.01	0.43	4.86	2.35	2.35	0.50	7.03	2.68	2.68	0.58	8.98
		19	-	-	-	-	2.75	1.68	0.59	9.38	2.73	2.02	0.59	9.22	2.70	2.36	0.58	9.06	2.70	2.69	0.58	9.07
		20	-	-	-	-	3.34	1.69	0.72	12.98	3.31	2.03	0.71	12.82	3.28	2.37	0.71	12.64	3.25	2.70	0.70	12.44
	5	15	1.18	1.18	0.20	1.17	1.52	1.52	0.26	1.51	1.85	1.85	0.32	2.15	2.17	2.17	0.37	3.30	2.49	2.49	0.43	4.79
		17	1.30	1.18	0.22	1.29	1.52	1.51	0.26	1.51	1.85	1.85	0.32	2.16	2.17	2.17	0.37	3.31	2.49	2.49	0.43	4.81
		19	-	-	-	-	2.26	1.49	0.39	3.69	2.23	1.83	0.38	3.58	2.23	2.17	0.38	3.58	2.50	2.50	0.43	4.83
		20	-	-	-	-	2.80	1.49	0.48	6.40	2.78	1.83	0.48	6.28	2.75	2.16	0.47	6.13	2.73	2.50	0.47	6.00
6	15	1.02	1.02	0.15	0.82	1.35	1.35	0.19	1.09	1.68	1.68	0.24	1.36	2.01	2.01	0.29	1.74	2.33	2.33	0.33	2.48	
	17	1.03	1.02	0.15	0.83	1.35	1.35	0.19	1.09	1.68	1.68	0.24	1.37	2.01	2.01	0.29	1.75	2.33	2.33	0.33	2.49	
	19	-	-	-	-	1.84	1.34	0.26	1.51	1.84	1.68	0.26	1.51	2.02	2.01	0.29	1.75	2.34	2.34	0.34	2.50	
	20	-	-	-	-	2.36	1.32	0.34	2.56	2.33	1.67	0.33	2.49	2.32	2.00	0.33	2.44	2.36	2.35	0.34	2.58	

Continue:

MDVF-400C4CE																							
EWT	ΔT	Indoor temp (W.B.)	Indoor temperature (D.B.)																				
			21				23				25				27				29				
			TC	SC	WF	WPD	TC	SC	WF	WPD	TC	SC	WF	WPD	TC	SC	WF	WPD	TC	SC	WF	WPD	
°C	°C	°C	kW	kW	m ³ /h	kPa	kW	kW	m ³ /h	kPa	kW	kW	m ³ /h	kPa	kW	kW	m ³ /h	kPa	kW	kW	m ³ /h	kPa	
11	3	15	1.19	1.19	0.34	2.56	1.52	1.52	0.43	4.96	1.86	1.86	0.53	7.68	2.20	2.20	0.63	10.21	2.53	2.53	0.72	12.99	
		17	1.30	1.18	0.37	3.27	1.52	1.52	0.43	4.99	1.86	1.86	0.53	7.70	2.20	2.20	0.63	10.24	2.54	2.54	0.72	13.03	
		19	-	-	-	-	2.36	1.53	0.67	11.53	2.34	1.87	0.67	11.30	2.32	2.21	0.66	11.16	2.54	2.54	0.73	13.08	
		20	-	-	-	-	2.94	1.54	0.84	16.75	2.92	1.88	0.83	16.51	2.89	2.22	0.82	16.25	2.86	2.55	0.82	15.97	
	4	15	1.02	1.02	0.22	1.21	1.36	1.36	0.29	1.76	1.68	1.68	0.36	3.06	2.01	2.01	0.43	4.92	2.34	2.34	0.50	6.93	
		17	1.02	1.01	0.22	1.21	1.36	1.36	0.29	1.76	1.68	1.68	0.36	3.08	2.01	2.01	0.43	4.95	2.35	2.35	0.50	6.95	
		19	-	-	-	-	1.83	1.34	0.39	3.88	1.82	1.68	0.39	3.81	2.01	2.01	0.43	4.97	2.35	2.35	0.50	6.98	
		20	-	-	-	-	2.40	1.34	0.51	7.27	2.38	1.68	0.51	7.12	2.35	2.02	0.50	6.98	2.36	2.36	0.51	7.04	
	5	15	0.85	0.85	0.15	0.80	1.19	1.19	0.20	1.11	1.52	1.52	0.26	1.46	1.85	1.85	0.32	2.22	2.16	2.16	0.37	3.43	
		17	0.85	0.85	0.15	0.80	1.19	1.19	0.20	1.12	1.52	1.52	0.26	1.47	1.85	1.85	0.32	2.23	2.17	2.17	0.37	3.44	
		19	-	-	-	-	1.41	1.18	0.24	1.32	1.53	1.53	0.26	1.48	1.85	1.85	0.32	2.24	2.17	2.17	0.37	3.46	
		20	-	-	-	-	1.92	1.17	0.33	2.47	1.90	1.51	0.33	2.40	1.91	1.85	0.33	2.45	2.17	2.17	0.37	3.47	
	6	15	0.68	0.68	0.10	0.52	1.02	1.02	0.15	0.78	1.35	1.35	0.19	1.04	1.68	1.68	0.24	1.30	2.01	2.01	0.29	1.75	
		17	0.68	0.68	0.10	0.52	1.02	1.02	0.15	0.78	1.35	1.35	0.19	1.04	1.69	1.69	0.24	1.30	2.01	2.01	0.29	1.76	
		19	-	-	-	-	1.05	1.03	0.15	0.81	1.36	1.36	0.19	1.04	1.69	1.69	0.24	1.30	2.02	2.02	0.29	1.77	
		20	-	-	-	-	1.45	1.01	0.21	1.11	1.47	1.36	0.21	1.13	1.69	1.68	0.24	1.31	2.02	2.02	0.29	1.77	
	13	3	15	0.86	0.86	0.25	1.32	1.19	1.19	0.34	2.71	1.52	1.52	0.44	5.19	1.86	1.86	0.53	7.66	2.20	2.20	0.63	10.17
			17	0.86	0.86	0.25	1.33	1.19	1.19	0.34	2.72	1.52	1.52	0.44	5.21	1.86	1.86	0.54	7.69	2.20	2.20	0.63	10.20
			19	-	-	-	-	1.40	1.18	0.40	4.23	1.51	1.49	0.43	5.16	1.87	1.87	0.54	7.71	2.21	2.21	0.63	10.24
			20	-	-	-	-	1.98	1.19	0.57	8.54	1.96	1.53	0.56	8.35	1.95	1.87	0.56	8.30	2.21	2.21	0.63	10.25
		4	15	0.68	0.68	0.15	0.77	1.02	1.02	0.22	1.16	1.35	1.35	0.29	1.80	1.68	1.68	0.36	3.22	2.00	2.00	0.43	5.10
			17	0.68	0.68	0.15	0.78	1.02	1.02	0.22	1.16	1.36	1.36	0.29	1.81	1.68	1.68	0.36	3.24	2.01	2.01	0.43	5.12
			19	-	-	-	-	1.03	1.03	0.22	1.17	1.36	1.36	0.29	1.82	1.68	1.68	0.36	3.25	2.01	2.01	0.43	5.06
			20	-	-	-	-	1.46	1.01	0.31	2.20	1.46	1.35	0.31	2.21	1.68	1.68	0.36	3.26	2.01	2.01	0.43	5.08
5		15	0.51	0.51	0.09	0.45	0.85	0.85	0.15	0.75	1.18	1.18	0.20	1.05	1.52	1.52	0.26	1.42	1.84	1.84	0.32	2.26	
		17	0.51	0.51	0.09	0.45	0.85	0.85	0.15	0.75	1.19	1.19	0.20	1.05	1.52	1.52	0.26	1.42	1.84	1.84	0.32	2.27	
		19	-	-	-	-	0.85	0.85	0.15	0.76	1.19	1.19	0.20	1.05	1.52	1.52	0.26	1.43	1.84	1.84	0.32	2.28	
		20	-	-	-	-	0.99	0.85	0.17	0.87	1.19	1.19	0.20	1.06	1.52	1.52	0.26	1.43	1.85	1.85	0.32	2.29	
6	15	0.35	0.35	0.05	0.25	0.68	0.68	0.10	0.49	1.02	1.02	0.15	0.74	1.35	1.35	0.19	0.98	1.68	1.68	0.24	1.24		
	17	0.35	0.35	0.05	0.25	0.68	0.68	0.10	0.50	1.02	1.02	0.15	0.74	1.35	1.35	0.19	0.98	1.68	1.68	0.24	1.25		
	19	-	-	-	-	0.69	0.69	0.10	0.50	1.02	1.02	0.15	0.74	1.35	1.35	0.19	0.98	1.69	1.69	0.24	1.25		
	20	-	-	-	-	0.70	0.70	0.10	0.50	1.02	1.02	0.15	0.74	1.36	1.36	0.19	0.99	1.69	1.69	0.24	1.25		
15	3	15	0.51	0.51	0.15	0.74	0.85	0.85	0.24	1.26	1.18	1.18	0.34	2.73	1.51	1.51	0.43	5.15	1.86	1.86	0.53	7.42	
		17	0.51	0.51	0.15	0.75	0.85	0.85	0.24	1.26	1.18	1.18	0.34	2.74	1.52	1.52	0.43	5.17	1.86	1.86	0.53	7.45	
		19	-	-	-	-	0.86	0.86	0.24	1.26	1.18	1.18	0.34	2.76	1.52	1.52	0.43	5.20	1.86	1.86	0.53	7.48	
		20	-	-	-	-	0.99	0.85	0.28	1.70	1.18	1.17	0.34	2.75	1.52	1.52	0.43	5.21	1.86	1.86	0.53	7.49	
	4	15	0.35	0.35	0.07	0.37	0.68	0.68	0.15	0.73	1.02	1.02	0.22	1.09	1.35	1.35	0.29	1.82	1.67	1.67	0.36	3.27	
		17	0.35	0.35	0.07	0.37	0.68	0.68	0.15	0.73	1.02	1.02	0.22	1.09	1.35	1.35	0.29	1.83	1.67	1.67	0.36	3.29	
		19	-	-	-	-	0.69	0.69	0.15	0.73	1.02	1.02	0.22	1.10	1.35	1.35	0.29	1.84	1.68	1.68	0.36	3.31	
		20	-	-	-	-	0.69	0.67	0.15	0.73	1.02	1.02	0.22	1.10	1.36	1.36	0.29	1.85	1.68	1.68	0.36	3.32	
	5	15	0.18	0.18	0.03	0.15	0.52	0.52	0.09	0.44	0.85	0.85	0.15	0.72	1.19	1.19	0.20	1.01	1.52	1.52	0.26	1.43	
		17	0.18	0.18	0.03	0.15	0.52	0.52	0.09	0.44	0.85	0.85	0.15	0.72	1.19	1.19	0.20	1.01	1.52	1.52	0.26	1.44	
		19	-	-	-	-	0.52	0.52	0.09	0.44	0.86	0.86	0.15	0.72	1.19	1.19	0.21	1.01	1.52	1.52	0.26	1.45	
		20	-	-	-	-	0.52	0.52	0.09	0.44	0.86	0.86	0.15	0.73	1.19	1.19	0.21	1.01	1.52	1.52	0.26	1.45	
6	15	-	-	-	-	0.35	0.35	0.05	0.24	0.69	0.69	0.10	0.47	1.02	1.02	0.15	0.71	1.35	1.35	0.19	0.94		
	17	-	-	-	-	0.35	0.35	0.05	0.24	0.69	0.69	0.10	0.47	1.02	1.02	0.15	0.71	1.35	1.35	0.19	0.94		
	19	-	-	-	-	0.35	0.35	0.05	0.24	0.69	0.69	0.10	0.48	1.02	1.02	0.15	0.71	1.36	1.36	0.19	0.94		
	20	-	-	-	-	0.35	0.35	0.05	0.24	0.69	0.69	0.10	0.48	1.02	1.02	0.15	0.71	1.36	1.36	0.19	0.94		

Cooling Capacity

MDVF-500C4CE																							
EWT	ΔT	Indoor temp (W.B.)	Indoor temperature (D.B.)																				
			21				23				25				27				29				
			TC	SC	WF	WPD	TC	SC	WF	WPD	TC	SC	WF	WPD	TC	SC	WF	WPD	TC	SC	WF	WPD	
°C	°C	°C	kW	kW	m³/h	kPa	kW	kW	m³/h	kPa	kW	kW	m³/h	kPa	kW	kW	m³/h	kPa	kW	kW	m³/h	kPa	
5	3	15	3.66	2.89	1.04	18.75	3.62	3.32	1.04	18.45	3.75	3.74	1.08	19.81	4.18	4.18	1.20	23.79	4.59	4.59	1.31	27.64	
		17	4.96	2.90	1.42	31.58	4.92	3.33	1.41	31.18	4.88	3.76	1.40	30.77	4.84	4.18	1.38	30.33	4.80	4.60	1.37	29.92	
		19	-	-	-	-	6.32	3.35	1.82	48.60	6.27	3.78	1.81	48.02	6.23	4.21	1.80	47.45	6.19	4.62	1.78	46.89	
		20	-	-	-	-	7.04	3.35	2.02	57.96	6.99	3.78	2.00	57.28	6.94	4.21	1.99	56.59	6.90	4.63	1.98	55.93	
	4	15	3.11	2.64	0.67	8.69	3.10	3.08	0.67	8.62	3.50	3.50	0.75	10.63	3.93	3.93	0.84	12.92	4.35	4.35	0.93	15.37	
		17	4.42	2.66	0.95	15.79	4.39	3.09	0.94	15.59	4.35	3.52	0.93	15.36	4.31	3.94	0.92	15.13	4.35	4.32	0.93	15.34	
		19	-	-	-	-	5.78	3.11	1.24	24.91	5.74	3.54	1.23	24.61	5.70	3.96	1.22	24.31	5.65	4.38	1.21	24.01	
		20	-	-	-	-	6.51	3.11	1.40	30.62	6.47	3.54	1.39	30.25	6.42	3.97	1.38	29.89	6.38	4.39	1.37	29.55	
	5	15	2.62	2.42	0.45	3.17	2.85	2.85	0.49	3.99	3.26	3.26	0.56	5.73	3.69	3.69	0.63	7.69	4.11	4.11	0.71	9.50	
		17	3.86	2.41	0.66	8.43	3.82	2.84	0.66	8.28	3.78	3.27	0.65	8.12	3.76	3.70	0.64	8.02	4.12	4.12	0.71	9.53	
		19	-	-	-	-	5.23	2.87	0.90	14.31	5.20	3.30	0.89	14.13	5.16	3.72	0.88	13.95	5.11	4.14	0.88	13.75	
		20	-	-	-	-	5.98	2.88	1.03	18.09	5.94	3.31	1.02	17.88	5.90	3.74	1.02	17.66	5.86	4.16	1.01	17.45	
6	15	2.23	2.23	0.32	1.65	2.64	2.64	0.38	2.09	3.06	3.06	0.44	2.98	3.47	3.47	0.50	4.21	3.88	3.88	0.56	5.69		
	17	3.33	2.18	0.48	3.76	3.30	2.62	0.47	3.67	3.28	3.05	0.47	3.61	3.47	3.47	0.50	4.23	3.89	3.89	0.56	5.72		
	19	-	-	-	-	4.66	2.62	0.67	8.54	4.62	3.05	0.66	8.42	4.58	3.48	0.66	8.28	4.54	3.90	0.65	8.14		
	20	-	-	-	-	5.40	2.63	0.77	11.06	5.36	3.06	0.77	10.92	5.32	3.49	0.76	10.78	5.28	3.91	0.76	10.64		
7	3	15	2.66	2.44	0.76	10.77	2.88	2.88	0.82	12.32	3.31	3.31	0.96	15.86	3.74	3.74	1.08	19.50	4.16	4.16	1.19	23.08	
		17	3.96	2.45	1.14	21.27	3.93	2.89	1.13	20.95	3.90	3.32	1.12	20.88	3.88	3.75	1.12	20.74	4.17	4.17	1.19	23.16	
		19	-	-	-	-	5.33	2.91	1.54	35.87	5.29	3.34	1.53	35.42	5.25	3.76	1.52	34.98	5.21	4.19	1.51	34.54	
		20	-	-	-	-	6.05	2.91	1.74	44.16	6.01	3.34	1.73	43.63	5.97	3.77	1.71	43.09	5.92	4.19	1.70	42.54	
	4	15	2.20	2.17	0.47	3.73	2.63	2.63	0.57	6.06	3.07	3.07	0.66	8.41	3.50	3.50	0.75	10.52	3.93	3.93	0.85	12.85	
		17	3.40	2.21	0.73	10.00	3.36	2.65	0.72	9.83	3.33	3.08	0.72	9.68	3.51	3.50	0.76	10.56	3.93	3.93	0.85	12.89	
		19	-	-	-	-	4.76	2.66	1.02	17.68	4.72	3.09	1.02	17.45	4.68	3.52	1.01	17.19	4.64	3.94	1.00	16.93	
		20	-	-	-	-	5.50	2.67	1.18	22.63	5.46	3.10	1.17	22.35	5.42	3.53	1.17	22.08	5.38	3.95	1.16	21.79	
	5	15	2.00	2.00	0.34	1.76	2.42	2.42	0.42	2.68	2.84	2.84	0.49	4.13	3.26	3.26	0.56	5.92	3.68	3.68	0.63	7.74	
		17	2.81	1.97	0.48	4.04	2.79	2.41	0.48	3.94	2.84	2.82	0.49	4.13	3.27	3.27	0.56	5.95	3.69	3.69	0.63	7.77	
		19	-	-	-	-	4.17	2.42	0.72	9.63	4.14	2.85	0.71	9.48	4.06	3.04	0.73	20.00	4.06	3.70	0.70	9.20	
		20	-	-	-	-	4.92	2.43	0.85	12.71	4.88	2.86	0.84	12.55	4.84	3.29	0.83	12.37	4.80	3.72	0.83	12.19	
6	15	1.78	1.78	0.26	1.24	2.21	2.21	0.32	1.55	2.63	2.63	0.38	2.13	3.05	3.05	0.44	3.12	3.46	3.46	0.50	4.41		
	17	2.31	1.77	0.33	1.65	2.33	2.22	0.33	1.67	2.64	2.64	0.38	2.14	3.05	3.05	0.44	3.14	3.46	3.46	0.50	4.43		
	19	-	-	-	-	3.56	2.18	0.51	4.73	3.53	2.61	0.51	4.60	3.50	3.04	0.50	4.50	3.51	3.47	0.50	4.53		
	20	-	-	-	-	4.30	2.18	0.62	7.31	4.26	2.62	0.61	7.19	4.22	3.05	0.60	7.06	4.18	3.47	0.60	6.92		
9	3	15	1.99	1.99	0.57	6.25	2.43	2.43	0.70	9.14	2.87	2.87	0.82	12.08	3.30	3.30	0.95	15.40	3.72	3.72	1.07	18.83	
		17	2.90	2.00	0.83	12.27	2.87	2.44	0.82	12.05	2.88	2.88	0.83	12.16	3.31	3.31	0.95	15.46	3.73	3.73	1.07	18.90	
		19	-	-	-	-	4.27	2.46	1.23	23.80	4.23	2.89	1.21	23.45	4.19	3.32	1.20	23.08	4.16	3.74	1.19	22.74	
		20	-	-	-	-	5.01	2.47	1.45	31.80	4.98	2.90	1.44	31.40	4.94	3.33	1.43	30.98	4.89	3.75	1.42	30.52	
	4	15	1.78	1.78	0.38	2.22	2.20	2.20	0.48	3.96	2.63	2.63	0.56	6.12	3.06	3.06	0.66	8.22	3.49	3.49	0.75	10.26	
		17	2.29	1.76	0.49	4.40	2.28	2.20	0.49	4.38	2.63	2.63	0.57	6.15	3.07	3.07	0.66	8.25	3.50	3.50	0.75	10.30	
		19	-	-	-	-	3.66	2.22	0.79	11.15	3.63	2.65	0.78	10.96	3.59	3.08	0.77	10.79	3.58	3.51	0.77	10.73	
		20	-	-	-	-	4.41	2.22	0.95	15.29	4.37	2.66	0.94	15.07	4.33	3.09	0.93	14.83	4.29	3.51	0.92	14.59	
	5	15	1.56	1.56	0.27	1.25	1.99	1.99	0.34	1.72	2.41	2.41	0.41	2.77	2.83	2.83	0.49	4.27	3.25	3.25	0.56	6.02	
		17	1.77	1.56	0.30	1.43	1.99	1.98	0.34	1.72	2.42	2.42	0.42	2.78	2.83	2.83	0.49	4.29	3.26	3.26	0.56	6.04	
		19	-	-	-	-	3.02	1.97	0.52	5.07	2.99	2.41	0.51	4.94	2.98	2.84	0.51	4.88	3.26	3.26	0.56	6.07	
		20	-	-	-	-	3.78	1.98	0.65	7.99	3.74	2.42	0.64	7.85	3.70	2.85	0.64	7.72	3.67	3.27	0.63	7.60	
6	15	1.34	1.34	0.19	0.88	1.77	1.77	0.25	1.17	2.20	2.20	0.32	1.49	2.62	2.62	0.38	2.15	3.03	3.03	0.43	3.20		
	17	1.37	1.36	0.20	0.90	1.78	1.78	0.25	1.17	2.21	2.21	0.32	1.49	2.63	2.63	0.38	2.16	3.04	3.04	0.44	3.21		
	19	-	-	-	-	2.47	1.77	0.35	1.86	2.47	2.21	0.35	1.85	2.64	2.64	0.38	2.20	3.05	3.05	0.44	3.23		
	20	-	-	-	-	3.14	1.75	0.45	3.53	3.11	2.18	0.45	3.43	3.09	2.62	0.44	3.36	3.11	3.06	0.45	3.42		

Continue:

MDVF-500C4CE																							
EWT	ΔT	Indoor temp (W.B.)	Indoor temperature (D.B.)																				
			21				23				25				27				29				
			TC	SC	WF	WPD	TC	SC	WF	WPD	TC	SC	WF	WPD	TC	SC	WF	WPD	TC	SC	WF	WPD	
°C	°C	°C	kW	kW	m³/h	kPa	kW	kW	m³/h	kPa	kW	kW	m³/h	kPa	kW	kW	m³/h	kPa	kW	kW	m³/h	kPa	
11	3	15	1.55	1.55	0.44	3.33	1.99	1.99	0.57	6.20	2.43	2.43	0.69	8.84	2.86	2.86	0.82	11.69	3.29	3.29	0.94	14.93	
		17	1.74	1.55	0.50	4.54	1.99	1.99	0.57	6.23	2.43	2.43	0.69	8.88	2.87	2.87	0.82	11.73	3.30	3.30	0.94	14.98	
		19	-	-	-	-	3.12	2.01	0.89	13.57	3.09	2.44	0.88	13.33	3.07	2.88	0.88	13.18	3.30	3.30	0.95	15.03	
		20	-	-	-	-	3.87	2.01	1.10	19.58	3.83	2.45	1.09	19.26	3.79	2.88	1.08	18.94	3.76	3.31	1.07	18.65	
	4	15	1.34	1.34	0.29	1.30	1.77	1.77	0.38	2.21	2.19	2.19	0.47	3.97	2.62	2.62	0.56	6.10	3.05	3.05	0.65	7.99	
		17	1.34	1.33	0.29	1.30	1.77	1.77	0.38	2.23	2.20	2.20	0.47	3.99	2.63	2.63	0.56	6.12	3.06	3.06	0.66	8.02	
		19	-	-	-	-	2.46	1.76	0.53	5.30	2.44	2.20	0.52	5.21	2.63	2.60	0.56	6.13	3.07	3.07	0.66	8.05	
		20	-	-	-	-	3.22	1.77	0.69	8.73	3.18	2.21	0.68	8.57	3.15	2.64	0.68	8.43	3.15	3.08	0.67	8.42	
	5	15	1.12	1.12	0.19	0.86	1.56	1.56	0.27	1.19	1.99	1.99	0.34	1.73	2.40	2.40	0.41	2.86	2.82	2.82	0.49	4.39	
		17	1.13	1.12	0.19	0.86	1.56	1.56	0.27	1.19	1.99	1.99	0.34	1.74	2.41	2.41	0.41	2.88	2.83	2.83	0.49	4.42	
		19	-	-	-	-	1.90	1.56	0.33	1.57	2.02	2.01	0.35	1.79	2.41	2.41	0.42	2.90	2.83	2.83	0.49	4.44	
		20	-	-	-	-	2.56	1.54	0.44	3.40	2.54	1.98	0.44	3.32	2.54	2.42	0.44	3.33	2.84	2.83	0.49	4.45	
	6	15	0.90	0.90	0.13	0.56	1.34	1.34	0.19	0.83	1.77	1.77	0.25	1.11	2.20	2.20	0.32	1.46	2.61	2.61	0.37	2.22	
		17	0.90	0.90	0.13	0.56	1.34	1.34	0.19	0.84	1.78	1.78	0.25	1.11	2.20	2.20	0.32	1.47	2.62	2.62	0.38	2.23	
		19	-	-	-	-	1.41	1.36	0.20	0.88	1.78	1.77	0.26	1.11	2.21	2.21	0.32	1.47	2.62	2.62	0.38	2.24	
		20	-	-	-	-	1.97	1.33	0.28	1.23	1.99	1.78	0.29	1.25	2.22	2.22	0.32	1.49	2.63	2.63	0.38	2.25	
	13	3	15	1.12	1.12	0.32	1.51	1.55	1.55	0.44	3.51	1.99	1.99	0.57	6.26	2.42	2.42	0.70	8.78	2.85	2.85	0.82	11.60
			17	1.12	1.12	0.32	1.51	1.55	1.55	0.45	3.53	1.99	1.99	0.57	6.29	2.43	2.43	0.70	8.82	2.86	2.86	0.82	11.64
			19	-	-	-	-	1.89	1.55	0.54	5.67	1.98	1.93	0.57	6.21	2.43	2.43	0.70	8.85	2.87	2.87	0.82	11.69
			20	-	-	-	-	2.64	1.56	0.76	10.13	2.61	2.00	0.75	9.94	2.60	2.44	0.75	9.87	2.87	2.86	0.82	11.71
		4	15	0.90	0.90	0.19	0.83	1.34	1.34	0.29	1.25	1.76	1.76	0.38	2.32	2.19	2.19	0.47	4.13	2.61	2.61	0.56	6.04
			17	0.90	0.90	0.19	0.83	1.34	1.34	0.29	1.25	1.77	1.77	0.38	2.33	2.19	2.19	0.47	4.15	2.62	2.62	0.56	6.06
			19	-	-	-	-	1.37	1.36	0.30	1.29	1.77	1.77	0.38	2.34	2.20	2.20	0.47	4.18	2.63	2.63	0.56	6.08
			20	-	-	-	-	1.95	1.32	0.42	3.04	1.94	1.77	0.42	3.02	2.20	2.18	0.47	4.18	2.63	2.63	0.56	6.10
5		15	0.68	0.68	0.12	0.49	1.12	1.12	0.19	0.80	1.55	1.55	0.27	1.12	1.98	1.98	0.34	1.73	2.39	2.39	0.41	2.91	
		17	0.68	0.68	0.12	0.49	1.12	1.12	0.19	0.81	1.55	1.55	0.27	1.12	1.98	1.98	0.34	1.74	2.40	2.40	0.41	2.92	
		19	-	-	-	-	1.12	1.11	0.19	0.81	1.56	1.56	0.27	1.13	1.99	1.99	0.34	1.75	2.40	2.40	0.41	2.94	
		20	-	-	-	-	1.35	1.12	0.23	0.97	1.57	1.57	0.27	1.14	1.99	1.99	0.34	1.76	2.41	2.41	0.41	2.95	
6		15	0.46	0.46	0.07	0.27	0.90	0.90	0.13	0.53	1.34	1.34	0.19	0.79	1.77	1.77	0.25	1.04	2.19	2.19	0.31	1.44	
		17	0.46	0.46	0.07	0.27	0.90	0.90	0.13	0.53	1.34	1.34	0.19	0.79	1.77	1.77	0.25	1.05	2.20	2.20	0.31	1.45	
		19	-	-	-	-	0.90	0.90	0.13	0.53	1.34	1.34	0.19	0.79	1.77	1.77	0.25	1.05	2.20	2.20	0.31	1.46	
		20	-	-	-	-	0.93	0.92	0.13	0.55	1.34	1.34	0.19	0.79	1.78	1.78	0.25	1.05	2.20	2.20	0.32	1.46	
15		3	15	0.67	0.67	0.19	0.80	1.11	1.11	0.32	1.48	1.54	1.54	0.44	3.53	1.98	1.98	0.56	6.06	2.41	2.41	0.69	8.49
			17	0.68	0.68	0.19	0.80	1.12	1.12	0.32	1.49	1.54	1.54	0.44	3.55	1.98	1.98	0.57	6.09	2.42	2.42	0.69	8.52
			19	-	-	-	-	1.12	1.12	0.32	1.49	1.55	1.55	0.44	3.57	1.98	1.98	0.57	6.11	2.42	2.42	0.69	8.56
			20	-	-	-	-	1.32	1.11	0.38	2.33	1.54	1.52	0.44	3.54	1.99	1.99	0.57	6.12	2.43	2.43	0.69	8.58
		4	15	0.46	0.46	0.10	0.40	0.90	0.90	0.19	0.78	1.33	1.33	0.29	1.20	1.75	1.75	0.38	2.35	2.18	2.18	0.47	4.15
			17	0.46	0.46	0.10	0.40	0.90	0.90	0.19	0.78	1.34	1.34	0.29	1.21	1.76	1.76	0.38	2.36	2.18	2.18	0.47	4.17
			19	-	-	-	-	0.90	0.90	0.19	0.78	1.34	1.34	0.29	1.21	1.76	1.76	0.38	2.38	2.19	2.19	0.47	4.19
			20	-	-	-	-	0.91	0.89	0.19	0.79	1.34	1.34	0.29	1.21	1.76	1.76	0.38	2.38	2.19	2.19	0.47	4.20
	5	15	0.23	0.23	0.04	0.16	0.68	0.68	0.12	0.47	1.12	1.12	0.19	0.77	1.55	1.55	0.27	1.08	1.97	1.97	0.34	1.80	
		17	0.23	0.23	0.04	0.16	0.68	0.68	0.12	0.47	1.12	1.12	0.19	0.77	1.55	1.55	0.27	1.08	1.98	1.98	0.34	1.81	
		19	-	-	-	-	0.68	0.68	0.12	0.47	1.12	1.12	0.19	0.77	1.56	1.56	0.27	1.09	1.98	1.98	0.34	1.82	
		20	-	-	-	-	0.68	0.68	0.12	0.47	1.12	1.12	0.19	0.77	1.56	1.56	0.27	1.09	1.98	1.98	0.34	1.83	
	6	15	-	-	-	-	0.46	0.46	0.07	0.26	0.90	0.90	0.13	0.51	1.33	1.33	0.19	0.75	1.76	1.76	0.25	1.00	
		17	-	-	-	-	0.46	0.46	0.07	0.26	0.90	0.90	0.13	0.51	1.34	1.34	0.19	0.75	1.77	1.77	0.25	1.00	
		19	-	-	-	-	0.46	0.46	0.07	0.26	0.90	0.90	0.13	0.51	1.34	1.34	0.19	0.75	1.77	1.77	0.25	1.00	
		20	-	-	-	-	0.46	0.46	0.07	0.26	0.91	0.91	0.13	0.51	1.34	1.34	0.19	0.76	1.77	1.77	0.25	1.00	

Cooling capacity modification coefficient table:**Heating Capacity:**

Δt: Temperature Difference (°C) **TH:** Total Heating Capacity (kW) **WF:** Water Flow (m³/h) **WPD:** Water Pressure Drop (kPa)

Four-way Cassette

MDVF-600C4E													
EWT	ΔT	Indoor temperature (W.B.)											
		16			18			20			22		
		TH	WF	WPD	TH	WF	WPD	TH	WF	WPD	TH	WF	WPD
°C	°C	kW	m ³ /h	kPa	kW	m ³ /h	kPa	kW	m ³ /h	kPa	kW	m ³ /h	kPa
40	8	4.90	0.53	3.91	4.26	0.46	3.08	3.62	0.39	2.29	3.01	0.32	1.45
	10	4.26	0.37	1.96	3.64	0.31	1.30	3.06	0.26	0.81	2.45	0.21	0.55
	12	3.69	0.27	0.82	3.07	0.22	0.60	2.46	0.18	0.48	1.85	0.13	0.36
	14	3.09	0.19	0.53	2.47	0.15	0.42	1.85	0.11	0.32	1.24	0.08	0.21
	16	2.48	0.13	0.39	1.87	0.10	0.29	1.25	0.07	0.20	0.64	0.03	0.10
45	8	6.47	0.70	6.11	5.83	0.63	5.11	5.19	0.56	4.20	4.56	0.49	3.37
	10	5.84	0.50	3.54	5.20	0.45	2.90	4.56	0.39	2.32	3.93	0.34	1.69
	12	5.20	0.37	2.10	4.57	0.33	1.54	3.96	0.29	1.05	3.37	0.24	0.68
	14	4.61	0.28	1.02	4.00	0.25	0.71	3.39	0.21	0.53	2.77	0.17	0.43
	16	4.03	0.22	0.57	3.41	0.18	0.48	2.79	0.15	0.39	2.17	0.12	0.31
50	8	8.03	0.87	8.65	7.39	0.80	7.48	6.74	0.73	6.40	6.11	0.66	5.40
	10	7.42	0.64	5.20	6.77	0.59	4.45	6.13	0.53	3.75	5.50	0.48	3.12
	12	6.79	0.49	3.29	6.14	0.44	2.78	5.50	0.40	2.30	4.86	0.35	1.84
	14	6.15	0.38	2.15	5.50	0.34	1.71	4.88	0.30	1.27	4.27	0.26	0.89
	16	5.54	0.30	1.23	4.92	0.27	0.89	4.32	0.23	0.64	3.71	0.20	0.48
55	8	9.59	1.03	11.51	8.94	0.96	10.18	8.29	0.89	8.94	7.65	0.82	7.78
	10	8.99	0.78	7.06	8.34	0.72	6.20	7.69	0.66	5.40	7.05	0.61	4.65
	12	8.37	0.60	4.58	7.72	0.55	3.99	7.07	0.51	3.44	6.43	0.46	2.93
	14	7.75	0.48	3.12	7.10	0.44	2.69	6.45	0.40	2.29	5.81	0.36	1.91
	16	7.11	0.38	2.16	6.45	0.35	1.82	5.81	0.31	1.45	5.19	0.28	1.10
60	8	11.17	1.21	14.75	10.50	1.13	13.19	9.84	1.06	11.79	9.19	0.99	10.47
	10	10.56	0.91	9.09	9.89	0.85	8.13	9.24	0.80	7.22	8.60	0.74	6.37
	12	9.95	0.72	6.05	9.29	0.67	5.37	8.64	0.62	4.74	7.99	0.58	4.15
	14	9.33	0.57	4.17	8.68	0.53	3.68	8.03	0.49	3.22	7.38	0.45	2.79
	16	8.71	0.47	2.97	8.05	0.43	2.60	7.40	0.40	2.25	6.75	0.36	1.93

Heating Capacity:

Δt: Temperature Difference (°C) **TH:** Total Heating Capacity (kW) **WF:** Water Flow (m³/h) **WPD:** Water Pressure Drop (kPa)

MDVF-750C4E													
EWT	ΔT	Indoor temperature (W.B.)											
		16			18			20			22		
		TH	WF	WPD	TH	WF	WPD	TH	WF	WPD	TH	WF	WPD
°C	°C	kW	m ³ /h	kPa	kW	m ³ /h	kPa	kW	m ³ /h	kPa	kW	m ³ /h	kPa
40	8	5.33	0.58	4.51	4.64	0.50	3.55	3.94	0.42	2.69	3.26	0.35	1.79
	10	4.60	0.40	2.36	3.93	0.34	1.60	3.29	0.28	0.99	2.66	0.23	0.61
	12	3.98	0.29	0.99	3.33	0.24	0.67	2.67	0.19	0.51	2.01	0.14	0.39
	14	3.34	0.21	0.56	2.67	0.16	0.45	2.01	0.12	0.34	1.35	0.08	0.23
	16	2.68	0.14	0.41	2.02	0.11	0.31	1.35	0.07	0.21	0.69	0.04	0.11
45	8	7.07	0.76	7.10	6.37	0.69	5.94	5.68	0.61	4.88	4.99	0.54	3.91
	10	6.37	0.55	4.09	5.67	0.49	3.36	4.97	0.43	2.69	4.27	0.37	2.04
	12	5.65	0.41	2.47	4.95	0.36	1.88	4.27	0.31	1.31	3.65	0.26	0.84
	14	4.97	0.31	1.26	4.33	0.27	0.86	3.68	0.23	0.60	3.02	0.19	0.46
	16	4.37	0.24	0.65	3.70	0.20	0.51	3.03	0.16	0.42	2.37	0.13	0.33
50	8	8.80	0.95	10.10	8.09	0.87	8.74	7.39	0.80	7.49	6.70	0.72	6.32
	10	8.12	0.70	6.06	7.42	0.64	5.18	6.72	0.58	4.38	6.02	0.52	3.63
	12	7.42	0.53	3.82	6.72	0.48	3.22	6.01	0.43	2.67	5.31	0.38	2.16
	14	6.70	0.41	2.49	5.99	0.37	2.04	5.30	0.33	1.57	4.63	0.29	1.11
	16	5.99	0.32	1.51	5.33	0.29	1.12	4.69	0.25	0.79	4.04	0.22	0.55
55	8	10.52	1.13	13.47	9.81	1.06	11.93	9.10	0.98	10.49	8.40	0.91	9.13
	10	9.86	0.85	8.26	9.15	0.79	7.26	8.44	0.73	6.32	7.74	0.67	5.45
	12	9.17	0.66	5.35	8.46	0.61	4.66	7.76	0.56	4.02	7.06	0.51	3.42
	14	8.49	0.52	3.63	7.78	0.48	3.13	7.07	0.44	2.66	6.36	0.39	2.23
	16	7.77	0.42	2.50	7.05	0.38	2.13	6.34	0.34	1.75	5.65	0.30	1.36
60	8	12.25	1.32	17.31	11.53	1.25	15.58	10.82	1.17	13.87	10.11	1.09	12.33
	10	11.58	1.00	10.66	10.86	0.94	9.54	10.15	0.88	8.49	9.45	0.81	7.50
	12	10.92	0.79	7.08	10.20	0.73	6.30	9.49	0.68	5.56	8.79	0.63	4.88
	14	10.24	0.63	4.88	9.52	0.59	4.31	8.81	0.54	3.77	8.11	0.50	3.27
	16	9.55	0.52	3.48	8.83	0.48	3.04	8.12	0.44	2.63	7.41	0.40	2.26

Heating Capacity:**Δt:** Temperature Difference (°C)**TH:** Total Heating Capacity (kW)**WF:** Water Flow (m³/h)**WPD:** Water Pressure Drop (kPa)

MDVF-850C4E													
EWT	ΔT	Indoor temperature (W.B.)											
		16			18			20			22		
		TH	WF	WPD	TH	WF	WPD	TH	WF	WPD	TH	WF	WPD
°C	°C	kW	m ³ /h	kPa	kW	m ³ /h	kPa	kW	m ³ /h	kPa	kW	m ³ /h	kPa
40	8	5.80	0.63	2.61	5.03	0.54	1.93	4.30	0.46	1.28	3.60	0.39	0.79
	10	5.06	0.44	1.06	4.36	0.38	0.73	3.62	0.31	0.54	2.90	0.25	0.43
	12	4.37	0.31	0.56	3.63	0.26	0.46	2.90	0.21	0.37	2.17	0.16	0.28
	14	3.62	0.22	0.41	2.89	0.18	0.33	2.16	0.13	0.24	1.44	0.09	0.16
	16	2.89	0.16	0.30	2.16	0.12	0.22	1.44	0.08	0.15	0.78	0.04	0.08
45	8	7.77	0.84	4.17	6.99	0.75	3.48	6.21	0.67	2.85	5.43	0.59	2.27
	10	6.94	0.60	2.38	6.16	0.53	1.87	5.41	0.47	1.36	4.69	0.40	0.93
	12	6.17	0.44	1.18	5.46	0.39	0.84	4.74	0.34	0.60	4.01	0.29	0.46
	14	5.50	0.34	0.59	4.75	0.29	0.48	4.01	0.25	0.41	3.28	0.20	0.33
	16	4.76	0.26	0.44	4.02	0.22	0.37	3.28	0.18	0.30	2.55	0.14	0.24
50	8	9.71	1.05	5.95	8.92	0.96	5.15	8.14	0.88	4.40	7.36	0.79	3.71
	10	8.92	0.77	3.56	8.13	0.70	3.04	7.35	0.64	2.56	6.57	0.57	2.12
	12	8.09	0.58	2.22	7.30	0.52	1.84	6.53	0.47	1.44	5.79	0.42	1.05
	14	7.29	0.45	1.27	6.56	0.40	0.96	5.85	0.36	0.70	5.13	0.32	0.51
	16	6.63	0.36	0.68	5.90	0.32	0.52	5.15	0.28	0.43	4.41	0.24	0.37
55	8	11.63	1.25	7.95	10.84	1.17	7.04	10.06	1.08	6.18	9.28	1.00	5.38
	10	10.87	0.94	4.87	10.08	0.87	4.27	9.29	0.80	3.72	8.51	0.74	3.20
	12	10.08	0.72	3.14	9.28	0.67	2.73	8.48	0.61	2.35	7.71	0.55	1.99
	14	9.27	0.57	2.12	8.47	0.52	1.81	7.68	0.47	1.49	6.91	0.43	1.17
	16	8.44	0.46	1.35	7.68	0.41	1.07	6.95	0.37	0.82	6.24	0.34	0.61
60	8	13.57	1.46	10.16	12.77	1.38	9.19	11.97	1.29	8.22	11.19	1.21	7.31
	10	12.80	1.10	6.29	12.00	1.03	5.63	11.21	0.97	5.00	10.43	0.90	4.41
	12	12.04	0.87	4.17	11.23	0.81	3.69	10.44	0.75	3.26	9.65	0.69	2.85
	14	11.25	0.69	2.86	10.45	0.64	2.53	9.65	0.59	2.21	8.86	0.55	1.91
	16	10.44	0.56	2.02	9.63	0.52	1.77	8.83	0.48	1.51	8.05	0.43	1.25

Heating Capacity:

Δt: Temperature Difference (°C) **TH:** Total Heating Capacity (kW) **WF:** Water Flow (m³/h) **WPD:** Water Pressure Drop (kPa)

MDVF-950C4E													
EWT	ΔT	Indoor temperature (W.B.)											
		16			18			20			22		
		TH	WF	WPD	TH	WF	WPD	TH	WF	WPD	TH	WF	WPD
°C	°C	kW	m ³ /h	kPa	kW	m ³ /h	kPa	kW	m ³ /h	kPa	kW	m ³ /h	kPa
40	8	5.81	0.63	2.61	5.03	0.54	1.93	4.30	0.46	1.28	3.60	0.39	0.79
	10	5.06	0.44	1.06	4.36	0.38	0.73	3.63	0.31	0.54	2.89	0.25	0.43
	12	4.36	0.31	0.55	3.62	0.26	0.46	2.88	0.21	0.37	2.16	0.16	0.28
	14	3.61	0.22	0.40	2.87	0.18	0.32	2.15	0.13	0.24	1.43	0.09	0.16
	16	2.87	0.16	0.29	2.14	0.12	0.22	1.42	0.08	0.15	0.78	0.04	0.08
45	8	7.80	0.84	4.20	7.01	0.76	3.50	6.23	0.67	2.87	5.45	0.59	2.28
	10	6.95	0.60	2.38	6.16	0.53	1.88	5.41	0.47	1.37	4.69	0.40	0.93
	12	6.17	0.44	1.18	5.46	0.39	0.84	4.75	0.34	0.60	4.01	0.29	0.46
	14	5.49	0.34	0.59	4.75	0.29	0.48	4.01	0.25	0.41	3.27	0.20	0.33
	16	4.75	0.26	0.43	4.01	0.22	0.37	3.27	0.18	0.30	2.54	0.14	0.23
50	8	9.76	1.05	6.01	8.97	0.97	5.20	8.18	0.88	4.44	7.40	0.80	3.74
	10	8.96	0.77	3.58	8.16	0.71	3.06	7.37	0.64	2.57	6.59	0.57	2.13
	12	8.11	0.58	2.23	7.31	0.53	1.85	6.53	0.47	1.44	5.80	0.42	1.06
	14	7.30	0.45	1.27	6.56	0.40	0.96	5.85	0.36	0.70	5.14	0.32	0.51
	16	6.63	0.36	0.68	5.90	0.32	0.52	5.16	0.28	0.43	4.41	0.24	0.37
55	8	11.71	1.26	8.04	10.91	1.18	7.11	10.12	1.09	6.25	9.33	1.01	5.44
	10	10.93	0.94	4.91	10.13	0.88	4.31	9.34	0.81	3.75	8.56	0.74	3.23
	12	10.12	0.73	3.16	9.31	0.67	2.75	8.53	0.61	2.36	7.73	0.56	2.00
	14	9.29	0.57	2.13	8.49	0.52	1.82	7.69	0.47	1.50	6.93	0.43	1.18
	16	8.45	0.46	1.36	7.69	0.41	1.07	6.96	0.38	0.82	6.25	0.34	0.61
60	8	13.66	1.47	10.28	12.86	1.39	9.30	12.06	1.30	8.32	11.27	1.22	7.40
	10	12.89	1.11	6.35	12.08	1.04	5.69	11.28	0.97	5.06	10.49	0.90	4.46
	12	12.11	0.87	4.21	11.30	0.81	3.73	10.50	0.75	3.29	9.71	0.70	2.88
	14	11.30	0.70	2.89	10.50	0.65	2.55	9.70	0.60	2.22	8.90	0.55	1.92
	16	10.48	0.56	2.04	9.67	0.52	1.78	8.86	0.48	1.52	8.07	0.44	1.26

Heating Capacity:

Δt: Temperature Difference (°C) **TH:** Total Heating Capacity (kW) **WF:** Water Flow (m³/h) **WPD:** Water Pressure Drop (kPa)

MDVF-1200C4E													
EWT	ΔT	Indoor temperature (W.B.)											
		16			18			20			22		
		TH	WF	WPD	TH	WF	WPD	TH	WF	WPD	TH	WF	WPD
°C	°C	kW	m ³ /h	kPa	kW	m ³ /h	kPa	kW	m ³ /h	kPa	kW	m ³ /h	kPa
40	8	5.85	0.63	2.65	5.06	0.55	1.96	4.33	0.47	1.30	3.62	0.39	0.80
	10	5.09	0.44	1.08	4.38	0.38	0.74	3.65	0.32	0.54	2.91	0.25	0.43
	12	4.39	0.32	0.56	3.64	0.26	0.46	2.90	0.21	0.37	2.17	0.16	0.28
	14	3.63	0.22	0.41	2.89	0.18	0.32	2.16	0.13	0.24	1.43	0.09	0.16
	16	2.89	0.16	0.29	2.15	0.12	0.22	1.43	0.08	0.15	0.78	0.04	0.08
45	8	7.86	0.85	4.25	7.07	0.76	3.55	6.28	0.68	2.90	5.49	0.59	2.31
	10	7.00	0.60	2.41	6.21	0.54	1.91	5.44	0.47	1.39	4.72	0.41	0.95
	12	6.21	0.45	1.20	5.49	0.40	0.86	4.78	0.34	0.61	4.04	0.29	0.47
	14	5.53	0.34	0.60	4.78	0.29	0.49	4.03	0.25	0.41	3.29	0.20	0.33
	16	4.78	0.26	0.44	4.04	0.22	0.37	3.29	0.18	0.30	2.56	0.14	0.24
50	8	9.84	1.06	6.09	9.04	0.97	5.27	8.25	0.89	4.50	7.46	0.80	3.80
	10	9.03	0.78	3.63	8.23	0.71	3.10	7.43	0.64	2.61	6.64	0.57	2.15
	12	8.17	0.59	2.26	7.36	0.53	1.87	6.58	0.47	1.47	5.86	0.42	1.08
	14	7.34	0.45	1.29	6.60	0.41	0.98	5.89	0.36	0.71	5.17	0.32	0.52
	16	6.67	0.36	0.69	5.94	0.32	0.53	5.19	0.28	0.43	4.44	0.24	0.37
55	8	11.80	1.27	8.15	11.00	1.19	7.22	10.20	1.10	6.34	9.41	1.01	5.52
	10	11.02	0.95	4.98	10.21	0.88	4.37	9.41	0.81	3.80	8.63	0.75	3.27
	12	10.20	0.73	3.20	9.39	0.68	2.79	8.59	0.62	2.39	7.80	0.56	2.03
	14	9.37	0.58	2.15	8.55	0.53	1.85	7.75	0.48	1.53	6.98	0.43	1.20
	16	8.51	0.46	1.38	7.74	0.42	1.09	7.00	0.38	0.84	6.29	0.34	0.62
60	8	13.77	1.48	10.43	12.97	1.40	9.44	12.16	1.31	8.44	11.37	1.23	7.51
	10	12.99	1.12	6.44	12.18	1.05	5.77	11.38	0.98	5.13	10.58	0.91	4.53
	12	12.21	0.88	4.27	11.39	0.82	3.78	10.59	0.76	3.33	9.79	0.70	2.92
	14	11.39	0.70	2.92	10.58	0.65	2.58	9.78	0.60	2.25	8.97	0.55	1.95
	16	10.56	0.57	2.06	9.74	0.53	1.80	8.93	0.48	1.54	8.13	0.44	1.28

Heating Capacity:

Δt: Temperature Difference (°C) **TH:** Total Heating Capacity (kW) **WF:** Water Flow (m³/h) **WPD:** Water Pressure Drop (kPa)

MDVF-1500C4E													
EWT	ΔT	Indoor temperature (W.B.)											
		16			18			20			22		
		TH	WF	WPD	TH	WF	WPD	TH	WF	WPD	TH	WF	WPD
°C	°C	kW	m ³ /h	kPa	kW	m ³ /h	kPa	kW	m ³ /h	kPa	kW	m ³ /h	kPa
40	8	8.84	0.95	2.81	7.68	0.83	2.09	6.56	0.71	1.38	5.46	0.59	0.84
	10	7.75	0.67	1.16	6.63	0.57	0.78	5.51	0.48	0.58	4.40	0.38	0.46
	12	6.67	0.48	0.61	5.54	0.40	0.50	4.42	0.32	0.40	3.31	0.24	0.30
	14	5.57	0.34	0.45	4.44	0.27	0.36	3.32	0.20	0.27	2.22	0.14	0.18
	16	4.47	0.24	0.33	3.35	0.18	0.25	2.23	0.12	0.17	1.13	0.06	0.08
45	8	11.65	1.26	4.37	10.48	1.13	3.65	9.33	1.01	3.00	8.18	0.88	2.40
	10	10.52	0.91	2.54	9.36	0.81	2.01	8.22	0.71	1.46	7.10	0.61	0.98
	12	9.42	0.68	1.27	8.29	0.60	0.89	7.16	0.52	0.63	6.04	0.44	0.50
	14	8.35	0.51	0.63	7.21	0.44	0.52	6.08	0.37	0.44	4.96	0.31	0.36
	16	7.25	0.39	0.48	6.11	0.33	0.40	4.99	0.27	0.33	3.87	0.21	0.26
50	8	14.46	1.56	6.16	13.27	1.43	5.32	12.10	1.30	4.55	10.95	1.18	3.83
	10	13.34	1.15	3.71	12.16	1.05	3.17	10.99	0.95	2.67	9.84	0.85	2.22
	12	12.21	0.88	2.36	11.03	0.79	1.95	9.88	0.71	1.52	8.75	0.63	1.11
	14	11.09	0.68	1.35	9.95	0.61	1.01	8.82	0.54	0.73	7.70	0.47	0.54
	16	10.03	0.54	0.71	8.88	0.48	0.55	7.75	0.42	0.46	6.62	0.36	0.39
55	8	17.26	1.86	8.17	16.05	1.73	7.22	14.87	1.60	6.32	13.70	1.48	5.49
	10	16.15	1.40	5.02	14.95	1.29	4.40	13.78	1.19	3.83	12.61	1.09	3.29
	12	15.03	1.08	3.27	13.84	0.99	2.84	12.66	0.91	2.44	11.50	0.83	2.08
	14	13.91	0.86	2.23	12.72	0.79	1.91	11.55	0.71	1.57	10.40	0.64	1.22
	16	12.78	0.69	1.43	11.61	0.63	1.12	10.47	0.56	0.85	9.35	0.50	0.62
60	8	20.05	2.16	10.38	18.85	2.04	9.36	17.64	1.91	8.35	16.46	1.78	7.41
	10	18.95	1.63	6.44	17.74	1.53	5.75	16.55	1.43	5.10	15.37	1.33	4.49
	12	17.85	1.28	4.29	16.63	1.20	3.79	15.45	1.11	3.34	14.27	1.03	2.92
	14	16.73	1.03	2.97	15.53	0.96	2.61	14.34	0.88	2.28	13.17	0.81	1.98
	16	15.60	0.84	2.12	14.40	0.78	1.85	13.22	0.71	1.58	12.06	0.65	1.29

Compact four-way cassette**Heating Capacity:**

Δt: Temperature Difference (°C) **TH:** Total Heating Capacity (kW) **WF:** Water Flow (m³/h) **WPD:** Water Pressure Drop (kPa)

MDVF-300C4CE													
EWT	ΔT	Indoor temperature (W.B.)											
		16			18			20			22		
		TH	WF	WPD	TH	WF	WPD	TH	WF	WPD	TH	WF	WPD
°C	°C	kW	m ³ /h	kPa	kW	m ³ /h	kPa	kW	m ³ /h	kPa	kW	m ³ /h	kPa
40	8	2.36	0.25	5.07	2.05	0.22	4.01	1.75	0.19	2.95	1.46	0.16	1.85
	10	2.06	0.18	2.50	1.77	0.15	1.66	1.48	0.13	1.04	1.19	0.10	0.74
	12	1.79	0.13	1.06	1.49	0.11	0.80	1.20	0.09	0.64	0.90	0.07	0.49
	14	1.50	0.09	0.71	1.20	0.07	0.57	0.91	0.06	0.43	0.61	0.04	0.29
	16	1.21	0.07	0.52	0.92	0.05	0.40	0.61	0.03	0.27	0.31	0.02	0.14
45	8	3.10	0.33	7.87	2.80	0.30	6.59	2.50	0.27	5.43	2.20	0.24	4.36
	10	2.81	0.24	4.59	2.51	0.22	3.77	2.20	0.19	3.00	1.90	0.16	2.16
	12	2.51	0.18	2.69	2.21	0.16	1.96	1.92	0.14	1.34	1.63	0.12	0.88
	14	2.24	0.14	1.29	1.94	0.12	0.91	1.64	0.10	0.71	1.35	0.08	0.58
	16	1.96	0.11	0.77	1.66	0.09	0.64	1.36	0.07	0.53	1.06	0.06	0.41
50	8	3.84	0.41	11.09	3.54	0.38	9.61	3.23	0.35	8.23	2.93	0.32	6.96
	10	3.56	0.31	6.70	3.25	0.28	5.74	2.95	0.25	4.85	2.64	0.23	4.04
	12	3.27	0.23	4.26	2.96	0.21	3.60	2.65	0.19	3.00	2.35	0.17	2.36
	14	2.97	0.18	2.78	2.66	0.16	2.19	2.36	0.15	1.61	2.07	0.13	1.13
	16	2.68	0.14	1.56	2.39	0.13	1.13	2.09	0.11	0.82	1.80	0.10	0.64
55	8	4.59	0.50	14.79	4.28	0.46	13.03	3.97	0.43	11.45	3.66	0.39	9.98
	10	4.31	0.37	9.06	3.99	0.35	7.97	3.69	0.32	6.95	3.38	0.29	5.99
	12	4.02	0.29	5.90	3.71	0.27	5.15	3.40	0.24	4.44	3.09	0.22	3.79
	14	3.73	0.23	4.04	3.41	0.21	3.49	3.11	0.19	2.97	2.80	0.17	2.48
	16	3.43	0.18	2.81	3.12	0.17	2.34	2.81	0.15	1.85	2.51	0.14	1.39
60	8	5.33	0.57	18.71	5.02	0.54	16.93	4.71	0.51	15.15	4.40	0.47	13.40
	10	5.05	0.44	11.63	4.73	0.41	10.41	4.42	0.38	9.26	4.12	0.35	8.18
	12	4.76	0.34	7.76	4.45	0.32	6.91	4.14	0.30	6.10	3.83	0.28	5.35
	14	4.48	0.28	5.37	4.16	0.26	4.75	3.85	0.24	4.16	3.55	0.22	3.62
	16	4.19	0.23	3.85	3.87	0.21	3.38	3.56	0.19	2.92	3.25	0.18	2.51

Heating Capacity:

Δt: Temperature Difference (°C) **TH:** Total Heating Capacity (kW) **WF:** Water Flow (m³/h) **WPD:** Water Pressure Drop (kPa)

MDVF-400C4CE													
EWT	ΔT	Indoor temperature (W.B.)											
		16			18			20			22		
		TH	WF	WPD	TH	WF	WPD	TH	WF	WPD	TH	WF	WPD
°C	°C	kW	m ³ /h	kPa	kW	m ³ /h	kPa	kW	m ³ /h	kPa	kW	m ³ /h	kPa
40	8	2.83	0.31	2.59	2.46	0.27	1.90	2.11	0.23	1.26	1.77	0.19	0.78
	10	2.49	0.21	1.05	2.14	0.19	0.72	1.78	0.15	0.55	1.43	0.12	0.44
	12	2.15	0.15	0.57	1.79	0.13	0.48	1.43	0.10	0.38	1.08	0.08	0.29
	14	1.79	0.11	0.42	1.44	0.09	0.34	1.08	0.07	0.26	0.73	0.04	0.17
	16	1.45	0.08	0.31	1.09	0.06	0.23	0.73	0.04	0.16	0.39	0.02	0.08
45	8	3.76	0.41	4.10	3.39	0.37	3.43	3.02	0.33	2.82	2.65	0.29	2.26
	10	3.38	0.29	2.35	3.01	0.26	1.85	2.65	0.23	1.34	2.30	0.20	0.91
	12	3.03	0.22	1.16	2.68	0.19	0.83	2.33	0.17	0.60	1.97	0.14	0.47
	14	2.70	0.17	0.60	2.34	0.14	0.50	1.98	0.12	0.42	1.62	0.10	0.34
	16	2.35	0.13	0.45	1.99	0.11	0.38	1.63	0.09	0.31	1.27	0.07	0.25
50	8	4.68	0.50	5.81	4.31	0.46	5.03	3.93	0.42	4.31	3.56	0.38	3.64
	10	4.32	0.37	3.49	3.94	0.34	2.99	3.57	0.31	2.53	3.19	0.28	2.10
	12	3.94	0.28	2.20	3.56	0.26	1.81	3.19	0.23	1.41	2.83	0.20	1.03
	14	3.57	0.22	1.24	3.22	0.20	0.94	2.86	0.18	0.69	2.51	0.15	0.51
	16	3.25	0.18	0.67	2.89	0.16	0.53	2.53	0.14	0.44	2.17	0.12	0.38
55	8	5.60	0.60	7.73	5.22	0.56	6.85	4.85	0.52	6.02	4.47	0.48	5.25
	10	5.24	0.45	4.75	4.87	0.42	4.18	4.49	0.39	3.64	4.12	0.36	3.14
	12	4.88	0.35	3.08	4.50	0.32	2.69	4.12	0.30	2.32	3.75	0.27	1.97
	14	4.50	0.28	2.10	4.12	0.25	1.79	3.75	0.23	1.47	3.38	0.21	1.15
	16	4.13	0.22	1.32	3.76	0.20	1.04	3.40	0.18	0.80	3.05	0.16	0.60
60	8	6.52	0.70	9.90	6.14	0.66	8.91	5.76	0.62	7.98	5.38	0.58	7.10
	10	6.16	0.53	6.11	5.78	0.50	5.47	5.40	0.47	4.87	5.03	0.43	4.31
	12	5.81	0.42	4.07	5.42	0.39	3.61	5.04	0.36	3.19	4.67	0.34	2.80
	14	5.44	0.34	2.81	5.06	0.31	2.48	4.68	0.29	2.18	4.30	0.27	1.89
	16	5.07	0.27	2.00	4.68	0.25	1.75	4.30	0.23	1.49	3.93	0.21	1.22

Heating Capacity:

Δt: Temperature Difference (°C) **TH:** Total Heating Capacity (kW) **WF:** Water Flow (m³/h) **WPD:** Water Pressure Drop (kPa)

MDVF-500C4CE													
EWT	ΔT	Indoor temperature (W.B.)											
		16			18			20			22		
		TH	WF	WPD	TH	WF	WPD	TH	WF	WPD	TH	WF	WPD
°C	°C	kW	m ³ /h	kPa	kW	m ³ /h	kPa	kW	m ³ /h	kPa	kW	m ³ /h	kPa
40	8	3.70	0.40	3.01	3.22	0.35	2.34	2.75	0.30	1.61	2.30	0.25	0.98
	10	3.24	0.28	1.34	2.78	0.24	0.89	2.32	0.20	0.61	1.86	0.16	0.47
	12	2.80	0.20	0.62	2.34	0.17	0.51	1.87	0.13	0.41	1.41	0.10	0.31
	14	2.35	0.14	0.45	1.88	0.12	0.36	1.41	0.09	0.27	0.95	0.06	0.19
	16	1.89	0.10	0.33	1.42	0.08	0.25	0.96	0.05	0.17	0.49	0.03	0.09
45	8	4.89	0.53	4.69	4.40	0.47	3.93	3.92	0.42	3.23	3.45	0.37	2.60
	10	4.41	0.38	2.73	3.93	0.34	2.23	3.45	0.30	1.68	2.99	0.26	1.16
	12	3.94	0.28	1.47	3.48	0.25	1.05	3.02	0.22	0.72	2.56	0.18	0.52
	14	3.51	0.22	0.70	3.04	0.19	0.54	2.57	0.16	0.45	2.11	0.13	0.37
	16	3.06	0.17	0.48	2.59	0.14	0.41	2.12	0.11	0.34	1.65	0.09	0.26
50	8	6.07	0.65	6.63	5.58	0.60	5.74	5.09	0.55	4.92	4.62	0.50	4.15
	10	5.60	0.48	3.99	5.12	0.44	3.42	4.63	0.40	2.89	4.15	0.36	2.40
	12	5.13	0.37	2.53	4.64	0.33	2.14	4.16	0.30	1.73	3.69	0.26	1.30
	14	4.65	0.29	1.56	4.18	0.26	1.18	3.71	0.23	0.86	3.26	0.20	0.61
	16	4.22	0.23	0.83	3.75	0.20	0.62	3.28	0.18	0.48	2.81	0.15	0.40
55	8	7.24	0.78	8.80	6.75	0.73	7.79	6.26	0.68	6.85	5.78	0.62	5.96
	10	6.79	0.59	5.41	6.30	0.54	4.76	5.81	0.50	4.15	5.33	0.46	3.57
	12	6.32	0.45	3.52	5.83	0.42	3.07	5.34	0.38	2.65	4.86	0.35	2.25
	14	5.86	0.36	2.40	5.36	0.33	2.07	4.87	0.30	1.75	4.39	0.27	1.41
	16	5.37	0.29	1.62	4.89	0.26	1.30	4.41	0.24	1.00	3.95	0.21	0.74
60	8	8.42	0.91	11.20	7.93	0.86	10.10	7.43	0.80	9.06	6.95	0.75	8.05
	10	7.97	0.69	6.95	7.47	0.64	6.22	6.98	0.60	5.54	6.49	0.56	4.89
	12	7.51	0.54	4.63	7.02	0.51	4.12	6.52	0.47	3.63	6.03	0.43	3.18
	14	7.05	0.43	3.20	6.55	0.40	2.83	6.06	0.37	2.48	5.58	0.34	2.15
	16	6.58	0.35	2.29	6.08	0.33	2.00	5.59	0.30	1.74	5.10	0.27	1.47

Altitude modification coefficient table:

Altitude (m)	TC	SC	TH
500	0.98	0.95	0.95
1000	0.97	0.91	0.91
1500	0.95	0.86	0.86
2000	0.94	0.82	0.82
2500	0.93	0.78	0.78
3000	0.91	0.74	0.7

12. Exploded View

Four-way Cassette: MDVF-600C4E, MDVF-750C4E, MDVF-850C4E, MDVF-950C4E, MDVF-1200C4E, MDVF-1500C4E

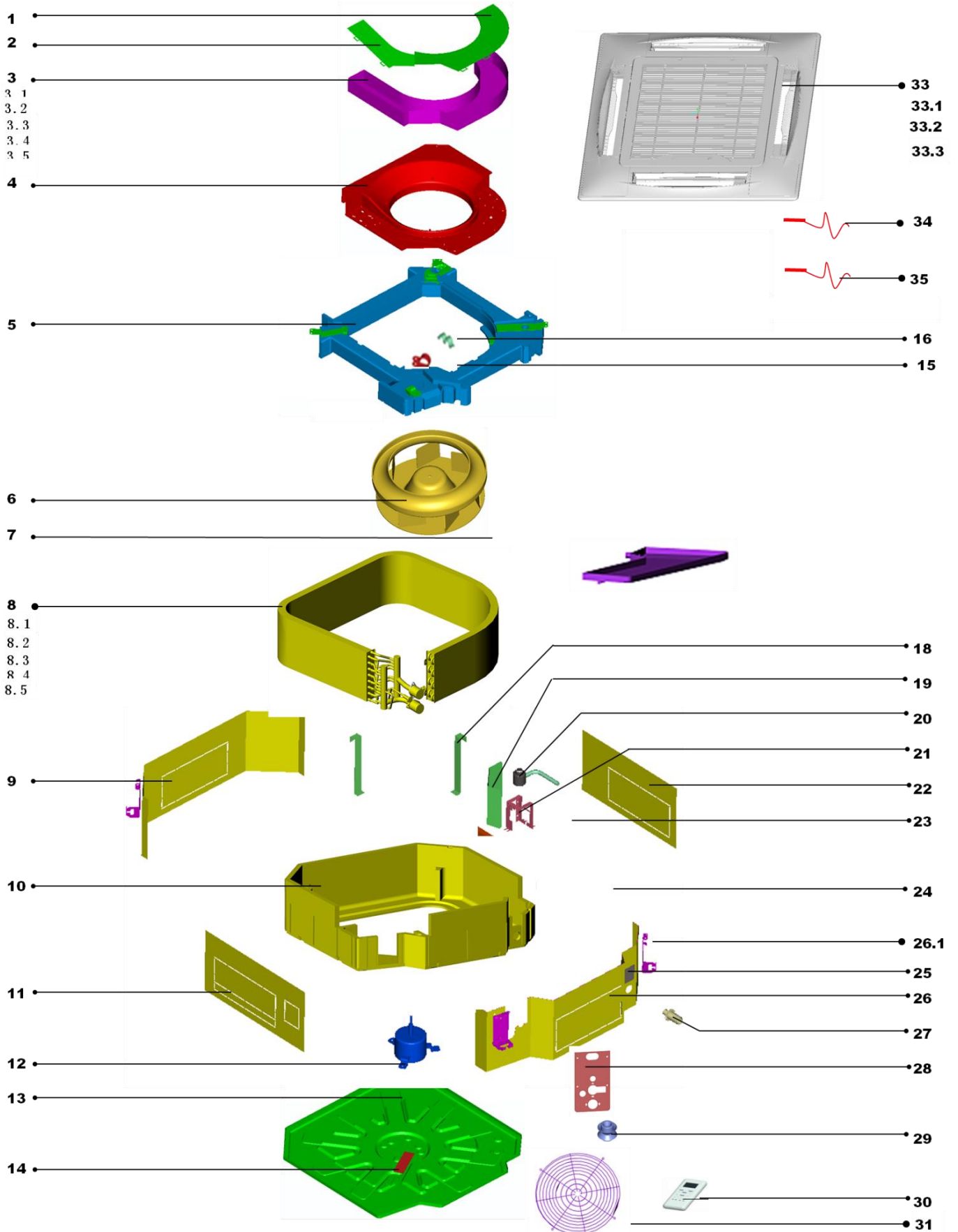

No.	Part Name	Qty	No.	Part Name	Qty
1	Electric control box head cover I	1	16	Wire clip	1
2	Electric control box head cover II	1	17	Drip tray assembly	1
3	Electric control box assembly of indoor unit	1	18	Evaporator fixing hook	3
3.1	Electric control box welded assembly	1	19	Water pump baffle plate	1
3.2	Transformer	1	20	Water drain pump subassembly	1
3.3	Capacitor	1	21	Water pump installation bracket subassembly	1
3.4	Four sides air outlet indoor main control plate	1	22	Front barrier IV subassembly	1
3.5	7-hole wiring terminal	1	23	Water pump pumping pipe grommet	1
4	Air inducting coils subassembly	1	24	Fan fixer	1
5	Foam subassembly, drain tray	1	25	Water finder cover subassembly	1
6	Fan assembly	1	26	Front barrier III subassembly	1
7	Evaporator fixing board	1	26.1	Install lifting lug	4
8	Evaporator assembly	1	27	Water pumping connect pipe	1
8.1	Evaporator	1	28	Exhalant tube seal plate subassembly	1
8.2	Evaporator output tube assembly	1	29	Water pump's rubber pad	1
8.3	Evaporator filter assembly	1	30	Remote controller	1
8.4	Barrel	1	31	Fan protecting net	1
8.5	Discharge assembly	1	32	Bracket, remote controller	1
9	Front barrier I subassembly	1	33	Front panel	1
10	Foam seat subassembly	1	33.1	Panel assembly	1
11	Front barrier II subassembly	1	33.2	Swing motor	2
12	Asynchronous dynamo	1	33.3	Room temperature sensor	1
13	Base pan welded assembly	1	34	Evaporator temperature sensor	1
14	Plate, wire	1	35	Drain water level sensor	1
15	Tandem, wire	1			

MDVF-600C4EE, MDVF-750C4EE, MDVF-850C4EE, MDVF-950C4EE, MDVF-1200C4EE

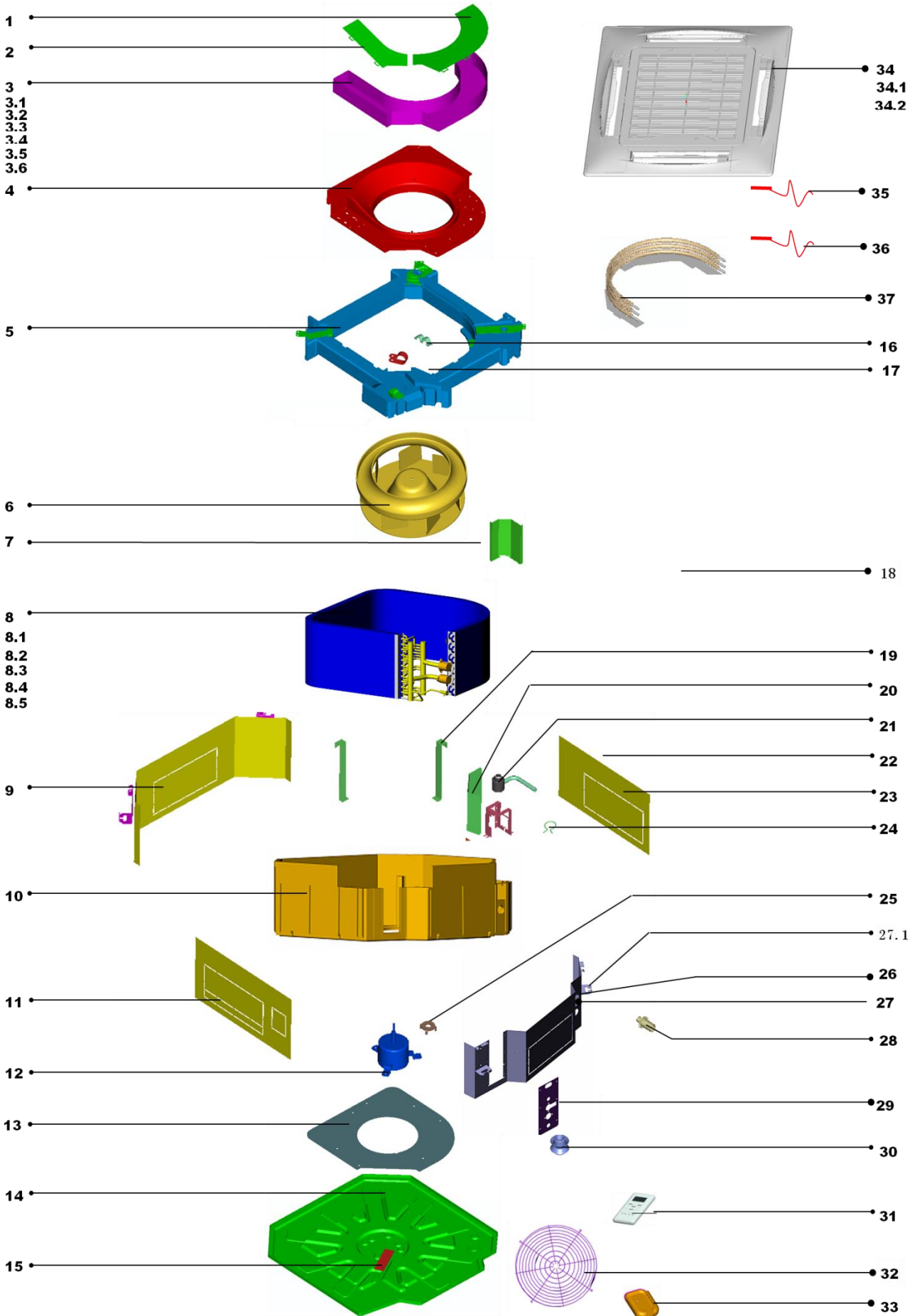

No	Part Name	Qty	No	Part Name	Qty
1	Electric control box head cover I	1	16	Tandem, wire	1
2	Electric control box head cover II	1	17	Wire clip	1
3	Electric control box assembly of indoor unit	1	18	Drip tray assembly	1
3.1	Electric control box welded assembly	1	19	Evaporator fixing hook	3
3.2	Voltage transformer	1	20	Water pump baffle plate	1
3.3	Supporter of electrical heater	1	21	Water drain pump subassembly	1
3.4	Capacitor	1	22	Water pump installation bracket subassembly	1
3.5	Four sides air outlet indoor main control plate	1	23	Front barrier IV subassembly	1
3.6	7-hole wiring terminal	1	24	Water pump pumping pipe grommet	1
4	Air inducing coils subassembly	1	25	Fan fixer	1
5	Foam subassembly, drain tray	1	26	Water finder cover subassembly	1
6	Fan assembly	1	27	Front barrier III subassembly	1
7	Evaporator fixing board	1	27.1	Install lifting lug	4
8	Evaporator assembly	1	28	Water pumping connect pipe	1
8.1	Evaporator	1	29	Exhalant tube seal plate subassembly	1
8.2	Evaporator output tube assembly	1	30	Water pump's rubber pad	1
8.3	Evaporator input tube assembly	1	31	Remote controller	1
8.4	Discharge assembly	1	32	Fan protecting net	1
8.5	Barrel	1	33	Bracket, remote controller	1
9	Front barrier I subassembly	1	34	Front panel	1
10	Foam seat subassembly	1	34.1	Swing motor	2
11	Front barrier II subassembly	1	34.2	Panel	1
12	Asynchronous dynamo	1	35	Evaporator temperature sensor	1
13	Base pan seat	1	36	Drain water level sensor	1
14	Base pan welded assembly	1	37	Auxiliary electrical heater assembly	1
15	Plate, wire	1			

Compact Four-way Cassette: MDVF-300C4CE MDVF-400C4CE MDVF-500C4CE

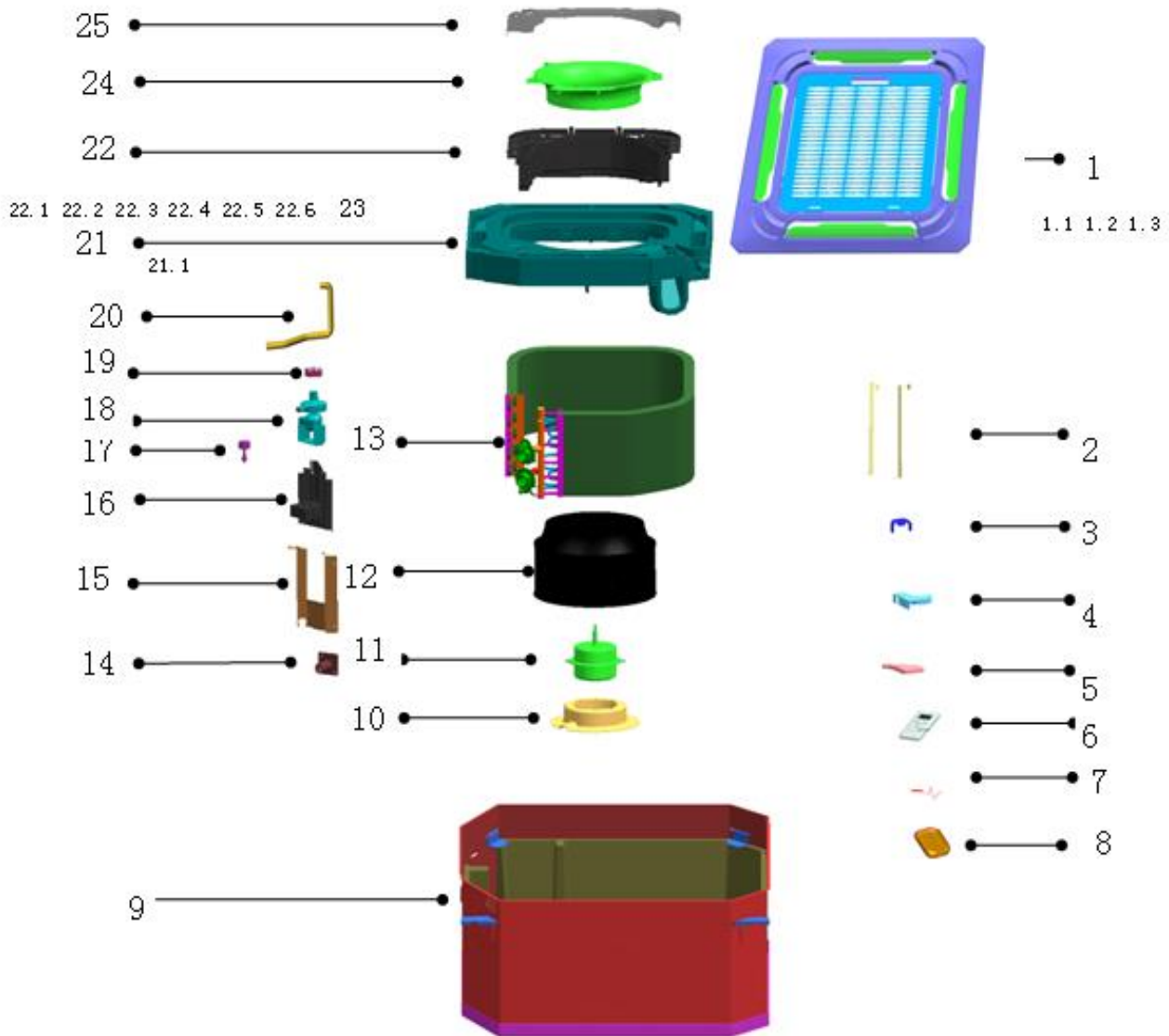

No.	Part Name	Quantity
1	Panel	1
1.1	Display board	1
1.2	Swing motor	1
1.3	Room temp sensor ass'y	1
2	Evaporator hang board	2
3	Wire clamp	1
4	Wire box	1
5	Cover box	1
6	Remote controller	1
7	Temp. sensor ass'y	1
8	Remote controller holder ass'y	1
9	Base ass'y	1
10	Motor installation base	1
11	Motor	1
12	Centrifugal fan	1
13	Evaporator ass'y	1
14	Connecting pipe	1
15	Evaporator fixing board	1

No.	Part Name	Quantity
16	Drain pump installation base	1
17	Water level sensor ass'y	1
18	Drain pump	1
19	Guard against block up net	1
20	Drain pipe	1
21	Drainage pan ass'y	1
21.1	Plug	1
22	E-part box ass'y	1
22.1	Main control board ass'y	1
22.2	Transformer	1
22.3	Wire joint	2
22.4	E-part box	1
22.5	Wire joint installation base	1
22.6	Fixture clip	3
23	Motor capacitor	1
24	Ring	1
25	E-Part box cover	1

13. Installation

13.1 Before installation

Please check whether the accessories are of full scope. If there are some fittings free from use, please restore them carefully.

13.2 Installation space

The indoor unit should be installed in a location that meets the following requirements:

- There is enough room for installation and maintenance.
- The ceiling is horizontal, and its structure can endure the weight of the indoor unit.
- The outlet and the inlet are not impeded, and the influence of external air is the least.
- The air flow can reach throughout the room.
- The connecting water pipe and drainpipe could be extracted out easily.
- There is no direct radiation from heaters.

Caution: Keep indoor unit, outdoor unit, power supply wiring and transmission wiring at least 1 meter away from televisions and radios. This is to prevent image interference and noise in those electrical appliances. (Noise may be generated depending on the conditions under which the electric wave is generated, even if 1 meter is kept.)

13.3 Installation procedures for fresh air intake duct connection

Preparing the connection hole

- Cut off the knockout hole on the side plate with a nipper.
- Cut the inner insulation of the hole portion with a cutter.

Placing the insulation

- Put the insulation tightly around the hole of the unit as shown. The ends of the side plate and the inner insulation must be completely adhered without leaving any clearance along the circumference of the hole. Make sure the inner surface of insulation tightly contacts the inner insulation edge and the side plate. (refer to fig.13.5)

13.4 Install the main body

A. The existing ceiling (to be horizontal)

- a. Cut a quadrangular hole of 880×880mm in the ceiling according to the shape of the installation paper board.
 - The center of the hole should be at the same position of that of the air conditioner body.
 - Determine the lengths and outlets of the connecting pipe, drain pipe and cables.
 - To balance the ceiling and to avoid vibration, please enforce the ceiling when necessary.
- b. Select the position of installation hooks according to the hook holes on the installation board.
 - Drill four holes of Ø12mm, 50~55mm deep at the selected positions on the ceiling. Then embed the expansible hooks (fittings).
 - Face the concave side of the installation hooks toward the expansible hooks. Determine the length of the installation hooks from the height of ceiling, and then cut off the unnecessary part.
 - If the ceiling is extremely high, please determine the length of the installation hook according to facts.
- c. Adjust the hexangular nuts on the four installation hooks evenly, to ensure the balance of the body.
 - If the drainpipe is awry, leakage will be caused by the malfunction of the water-level switch.
 - Adjust the position to ensure the gaps between the body and the four sides of ceiling are even. The body's lower part should sink into the ceiling for 10~12 mm (refer to fig.13.6).
 - In general, L is half of the screw length of the installation hook. (refer to fig.13.6)
 - Locate the air conditioner firmly by wrenching the nuts after having adjusted the body's position well. (refer to fig.13.7)

B. New built houses and ceilings

- a. In the case of new built house, the hook can be embedded in advance (refer to the A.b mentioned above). But it should be strong enough to bear the indoor unit and will not become loose because of concrete shrinking.

- b. After installing the body, please fasten the installation paper board onto the air conditioner with bolts (M6×12) to determine in advance the sizes and positions of the hole opening on ceiling. (refer to fig.13.8)
 - Please first guarantee the flatness and horizontal of ceiling when installing it.
 - Refer to the A.a mentioned above for others.
- c. Refer to the A.c mentioned above for installation.
- d. Remove the installation paper board.

Caution: After installing the body, the four bolts (M6×12) must be fastened to the air conditioner onto ensure the body is grounded well.

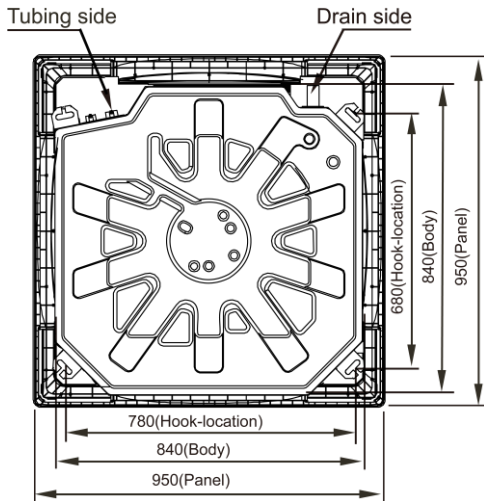

fig. 13.1

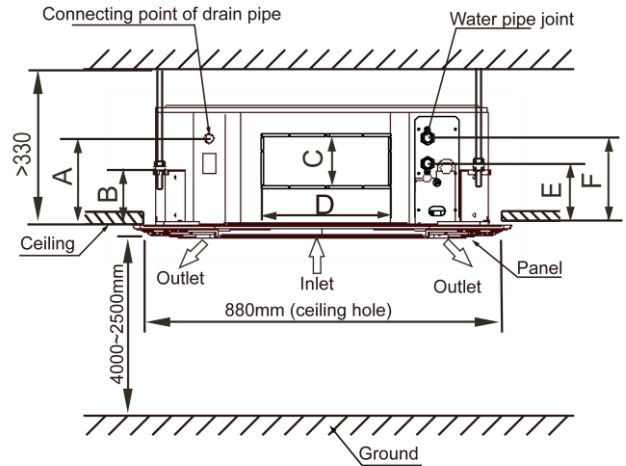

fig. 13.2

Table 13.1

Model	A	B	C	D	E	F
600CFM, 750CFM	180	140	85	350	145	195
850CFM, 950CFM, 1200CFM, 1500CFM	180	140	155	350	155	205

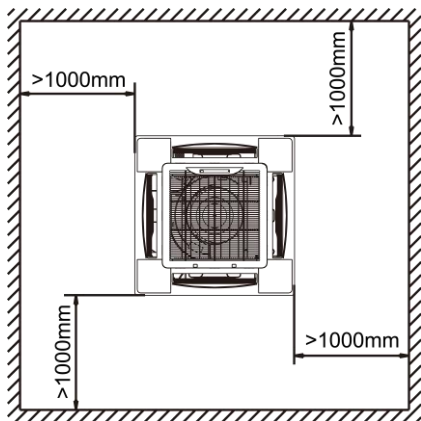

fig. 13.3

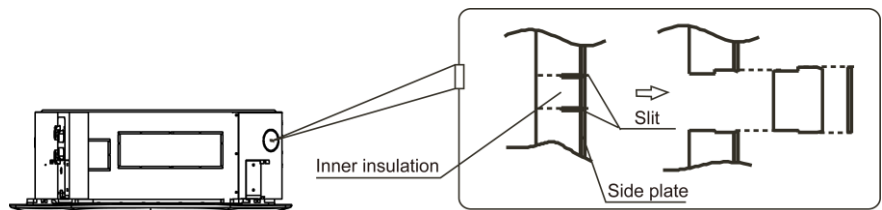

fig. 13.4

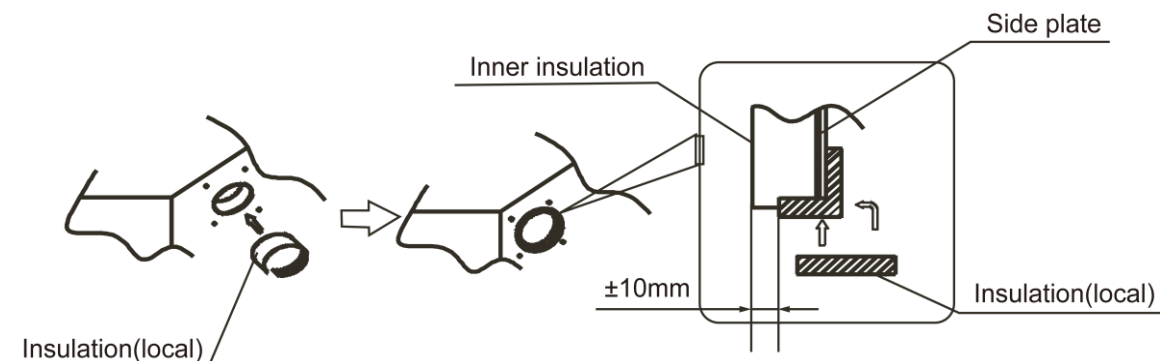

fig. 13.5

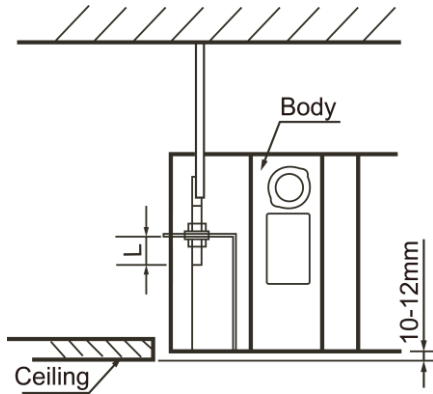

fig. 13.6

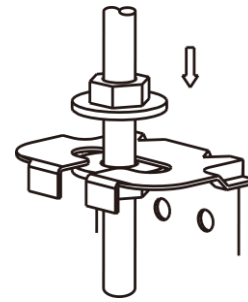

fig. 13.7

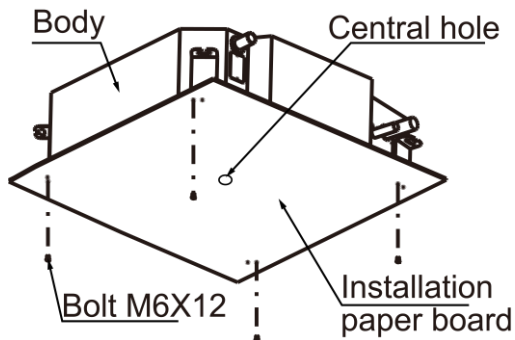

fig. 13.8

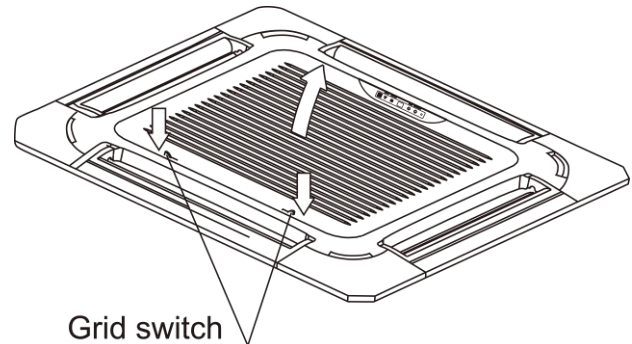

fig. 13.9

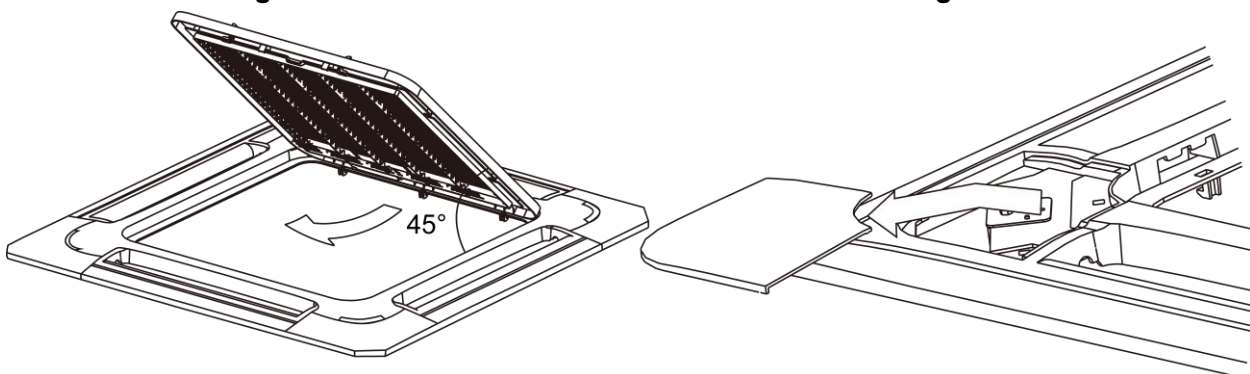

fig. 13.10

13.5 Install the panel

Caution:

Never put the panel face down on floor or against the wall, or on bulgy objects.

Never crash or strike it.

(1) Remove the air inlet grill.

- a. Slide two grid switches toward the middle at the same time, and then pull them up. (refer to fig. 13.9)
- b. Draw the grid up to an angle of about 45°, and remove it. (refer to fig. 13.10)

(2) Remove the installation covers at the four corners.

Wrench off the bolts, loose the rope of the installation covers, and remove them. (refer to fig. 13.10)

(3) Install the panel

- a. Align the swing motor on the panel to the tubing joints of the body properly.
- b. Fix hooks of the panel at swing motor and its opposite sides to the hooks of corresponding water receiver. Then hang the other two panel hooks onto corresponding hangers of the body.

Caution: Do not coil the wiring of the swing motor into the seal sponge.

- c. Adjust the four panel hook screws to keep the panel horizontal, and screw them up to the ceiling evenly.
- d. Regulate the panel in the direction of the arrow slightly to fit the panel's center to the center of the ceiling's opening. Guarantee that hooks of four corners are fixed well.

- e. Keep fastening the screws under the panel hooks, until the thickness of the sponge between the body and the panel's outlet has been reduced to about 4~6mm. The edge of the panel should contact with the ceiling well.
- If the gap between the panel and ceiling still exists after fastening the screws, the height of the indoor unit should be modified again.
 - You can modify the height of the indoor unit through the openings on the panel's four corners; if the lift of the indoor unit and the drainpipe is not influenced.

(4) Hang the air-in grid to the panel, and then connect the lead terminator of the swing motor and that of the control box with corresponding terminators on the body respectively.

(5) Relocate the air-in grid in the procedure of reversed order.

(6) Relocate the installation cover.

- Fasten the rope of installation cover on the bolt of the installation cover.
- Press the installation cover into the panel slightly.

13.6 Connect the Drain Pipe

Install the drainpipe of the indoor unit

- The drainpipe can use PVC pipe (external diameter about 37~39mm, inner diameter is 32mm).
- Joint drainpipe connector to the end side of water pumping pipe, and fix drainpipe together with water outflow pipe and thermal insulation tube by clasp of water outflow pipe (attached).

Caution: Don't use forcing strength to crack the water-pumping pipe.

- Water-pumping pipe and drainpipe from main body must be wrapped by insulation tube evenly, and bound by tighten band for obstructing air getting in and coagulation.
- Prevent from water backflow into unit inside during shutdown, the drain pipe shall place down side and drain water to outdoor (drain side), the gradient of the drain pipe should be higher than (1/100), without salient and water remain.(refer to fig.13.11a)
- When connecting drainpipe, don't drag the pipe that would pull the main unit. For this, please arrange bearing points every 0.8 to 1.0 meter to avoid pipe be bended (refer to fig.13.11b).
- When connect a lengthen drainpipe, apply protective tube to wrap its indoor parts for ensuring the lengthen part connected tightly.
- In case the drainpipe outlet is higher than pumping connective pipe of the main body, the drainpipe must be arranged upwards vertically by using connective assembly of the water outlet for vertical bending, and the height of the drainpipe shall set to the defrosting pan surface no more than 1000mm, otherwise, too much backflow while shutdown would leads to overflow (refer to fig.13.12).
- Base on the actual requirement to bend piping, and use connective assembly of water outlet in terminal box for pipe layout.

Caution: The joints in drain system must be sealed to avoid water leakage.

- The height from floor to the end of drainpipe or the bottom of drain slot must more than 50 mm. Don't immerse the end of drainpipe or the bottom of drain slot into water. When drain condensate liquid to raceway, please bend the drainpipe to a U-shaped hydroseal for avoiding stench transmitted by drainpipe to indoor.

Note: All the pictures in this manual are for explanation purpose only. They may be slightly different from the air-conditioner you purchased (depend on model).The actual shape shall prevail.

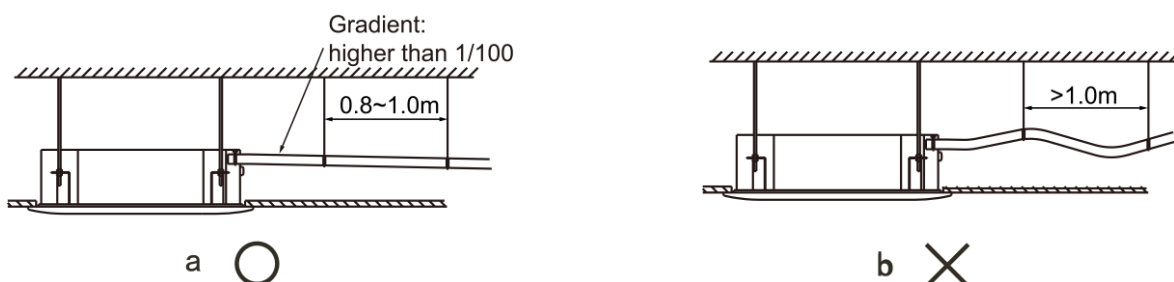

fig. 13.11

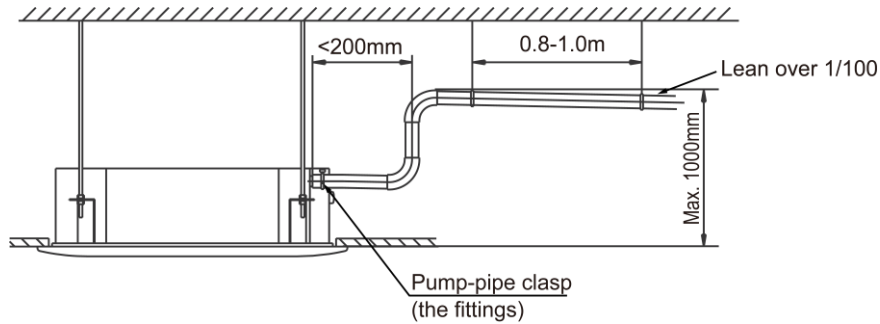

fig. 13.12

Drainage test

- Check whether the drainpipe is unhindered.
- New built house should have this test done before paving the ceiling.
 1. Remove the test cover, and stow water of about 2000ml to the water receiver through the stow tube.
 2. Turn on the power, and operate the air conditioner under the "COOLING" mode. Listen to the sound of the drain pump. Check whether the water is discharged well (a lag of 1min is allowed before discharging, according to the length of the drain pipe), and check whether water leaks from the joints.

Cautions: If there is any malfunction, please resolve it immediately.

3. Stop the air conditioner for three minutes, check if everything is ok. If the drain hose is located unreasonable, water overflow will cause the Alarm indicator lamp flashing (For both cooling and heating type or cooling only type), even the water leak out from the water receiver.
 4. Check the drain pump whether drain water immediately when alarm sound for the high water lever. If the water lever can't come down below to the limited water lever, the air conditioner will stop. Restart it until turn off the power and drain off all the water.
 5. Turn off the power, drain the water away.
- The drain plug is used to empty the water-receiver for maintenance of the air conditioner. Please stuff it imposition at all times during operation to avoid leakage.

13.7 Wiring

Caution:

- The air conditioner should use separate power supply with rated voltage.
- The external power supply to the air conditioner should have ground wiring, which is linked to the ground wiring of the indoor and outdoor unit.
- The wiring work should be done by qualified persons according to circuit drawing.
- An all-pole disconnection device which has at least 3mm separation distance in all pole and a residual current device (RCD) with the rating of above 10mA shall be incorporated in the fixed wiring according to the national rule.
- The appliance shall be installed in accordance with national wiring regulations.
- Be sure to locate the power wiring and the signal wirings well to avoid cross-disturbance.
- Do not turn on the power until you have checked carefully after wiring.

Note: Remark per EMC Directive 2004/108/EC for to prevent flicker impressions during the start of the compressor (technical process), following installation conditions do apply.

1. The power connection for the air conditioner has to be done at the main power distribution. The distribution has to be of low impedance; normally the required impedance reaches at a 32A fusing point.
2. No other equipment has to be connected with this power line.
3. For detailed installation acceptance please refer to your power supplier, if restrictions do apply for products like washing machines, air conditioners or electrical ovens.
4. For power details of the air conditioner refer to the rating plate of the product.
5. For any question contact your local dealer.

Connect the cable

- Disassemble the bolts from the cover. (If there isn't a cover on the outdoor unit, disassemble the bolts from the

maintenance board, and pull it in the direction of the arrow to remove the protection board.)

- Connect the connective cables to the terminals as identified with their respective marked numbers on the terminal block of indoor and outdoor units.
- Re-install the cover or the protection board.

AIR FLOW(m ³ /h)		510~2550
POWER	PHASE	1-phase
	FREQUENCY AND VOLT	220-240V~ 50Hz
CIRCUIT BREAKER/FUSE(A)		15/15
INDOOR UNIT POWER WIRING(mm ²)	BELOW 20m	Twisted pair wire 2.5mm ²
	BELOW 50m	Twisted pair wire 6mm ²
GROUND WIRING(mm ²)		2.5mm ²

Wiring figure

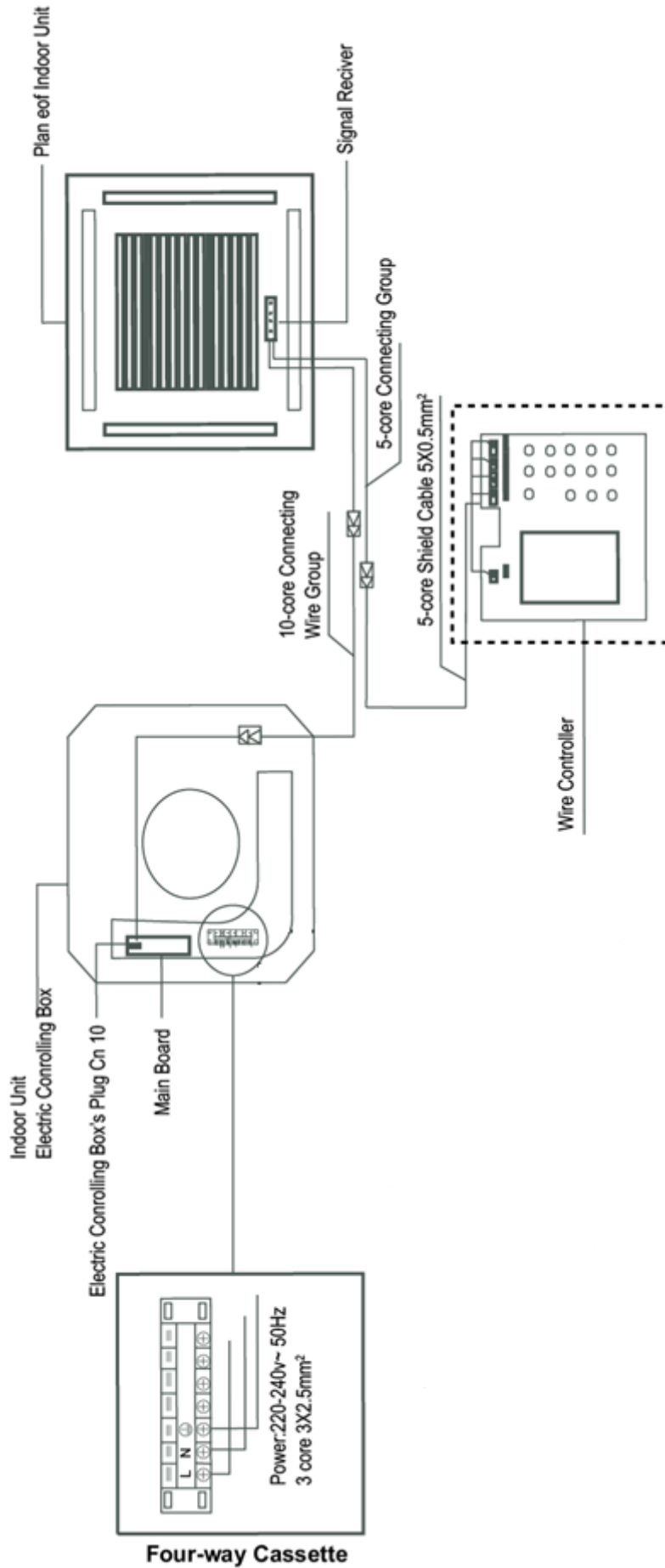

Note: If the supply cord is damaged, it must be replaced by the manufacturer or its service agent or a similarly qualified person in order to avoid a hazard.

13.8 Troubleshooting

13.8.1 Troubles and casuses of air conditioner

Symptoms	Causes	Solution
Unit does not start	<ul style="list-style-type: none"> Power failure. Power switch is off. Fuse of power switch may have burned. Batteries of remote controller exhausted or other problem of controller. 	<ul style="list-style-type: none"> Wait for the comeback of power. Switch on the power. Replace the fuse. Replace the batteries or check the controller.
Air flowing normally but completely can't cooling	<ul style="list-style-type: none"> Temperature is not setted correctly. 	<ul style="list-style-type: none"> Set the temperature properly.
Units start or stop frequently	<ul style="list-style-type: none"> Air or no concreting gas in the watering circuit. three-way valve is malfunction. Voltage is too high or too low. System circuit is blocked. Temperature is not setted correctly. 	<ul style="list-style-type: none"> Vacuum . Maintenance or change three-way valve. Install manostat. Find reasons and solution.
Low cooling effect	<ul style="list-style-type: none"> Indoor unit heat exchanger is dirty. The air filter is dirty. Inlet/outlet of indoor units is blocked. Doors and windows are open Sunlight directly shine. Too much heat resource. Leakage of water . 	<ul style="list-style-type: none"> Clean the heat exchanger. Clean the air filter. Eliminate all dirties and make air smooth. Close doors and windows. Make curtains in order to shelter from sunshine. Reduce heat source. AC cooling capacity reduces (normal). Check leakage .
Low heating effect	<ul style="list-style-type: none"> Doors and windows not completely closed. Leakage of water. 	<ul style="list-style-type: none"> Use heating device. Close doors and windows. Check leakage.

13.8.2 Troubles and causes of the remote controller

Symptoms	Causes	Solution
The fan speed can not be changed.	<ul style="list-style-type: none"> Check whether the MODE indicated on the display is "AUTO" 	When the automatic mode is selected, the air conditioner will automatically change the fan speed.
	<ul style="list-style-type: none"> Check whether the MODE indicated on the display is "DRY" 	When dry operation is selected, the air conditioner automatically change the fan speed. The fan speed can be selected during "COOL", "FAN ONLY", and "HEAT"
The remote controller signal is not transmitted even when the ON/OFF button is pushed.	<ul style="list-style-type: none"> Check whether the batteries in the remote controller are exhausted. 	The power supply is off.
The TEMP. indicator does not come on.	<ul style="list-style-type: none"> Check whether the MODE indicated on the display is FAN ONLY 	The temperature cannot be set during FAN mode.
The indication on the display disappears after a lapse of time.	<ul style="list-style-type: none"> Check whether the timer operation has come to an end when the TIMER OFF is indicated on the display. 	The air conditioner operation will stop up to the set time
The TIMER ON indicator goes off after a lapse of certain time.	<ul style="list-style-type: none"> Check whether the timer operation is started when the TIMER ON is indicated on the display. 	Up to the set time, the air conditioner will automatically start and the appropriate indicator will go off.
No receiving tone sounds from the indoor unit even when the ON/OFF button is pressed.	<ul style="list-style-type: none"> Check whether the signal transmitter of the remote controller is properly directed to the infrared signal receiver of the indoor unit when the ON/OFF button is pressed. 	Directly transmit the signal transmitter of the remote controller to the infrared signal receiver of the indoor unit, and then repeatedly push the ON/OFF button twice.

13.8.3 Malfunctions and malfunction code

If anything happens like the situation described below, please shut off the power supply of the unit and contact with the customer service center immediately.

Four-way Cassette

NO.	Malfunction	alarm lamp
1	Room temperature sensor check channel is abnormal.	E2
2	Evaporator sensor checking channel is abnormal.(T2C)	E3
3	Evaporator sensor checking channel is abnormal.(T2H)	E4
4	EEprom malfunction.	E7
5	Fan failure.	E8
6	Protection against freezing	P0
7	Excess water temperature protection	P1
8	Water-level switch malfunction.	EE
9	Not set models.	PF
10	Indoor unit switch at long-range controller is dialed to OFF.	----

Compact Four-way Cassette

NO.	Malfunction	running lamp	timer lamp	defrosting lamp	alarm lamp
1	Room temperature sensor checking channel is abnormal.	X	☆	X	X
2	Evaporator sensor checking channel is abnormal.(T2C)	☆	X	X	X
3	Evaporator sensor checking channel is abnormal.(T2H)	☆	X	X	X
4	EEprom malfunction.	☆	☆	X	X
5	Fan failure	☆	☆	☆	X
6	Protection against freezing	☆	X	X	☆
7	Excess water temperature protection	☆	X	☆	X
8	Water-level switch malfunction.	X	X	X	☆
9	Not set models.	☆	☆	☆	☆
10	Indoor unit switch at long-range controller is dialed to OFF.	----	----	----	----

(× Extinguish, ☆ Flash at 5Hz)

13.9 Test operation

- The test operation must be carried out after the entire installation has been completed.
- Please confirm the following points before the test operation:
 - The indoor unit and outdoor unit are installed properly.
 - Tubing and wiring are correctly completed.
 - The water pipe system is leakage-checked. The drainage is unimpeded.
 - The heating insulation works well.
 - The ground wiring is connected correctly.
 - The length of the tubing has been recorded.
 - The power voltage fits the rated voltage of the air conditioner.
 - There is no obstacle at the outlet and inlet of the outdoor and indoor units.
 - The air conditioner is pre-heated by turning on the power.
- According to the user's requirement, install the remote controller frame where the remote controller's signal can reach the indoor unit smoothly.
- Test operation

Set the air conditioner under the mode of "COOLING" with the remote controller, and check the following points. If there is any malfunction, please resolve it according to the chapter "Troubleshooting" in the "Owner's Manual".

- Whether the switch on the remote controller works well.
- Whether the buttons on the remote controller works well.
- Whether the air flow louver moves normally.
- Whether the room temperature is adjusted well.
- Whether the indicator lights normally.
- Whether the temporary buttons works well.
- Whether the drainage is normal.
- Whether there is vibration or abnormal noise during operation.
- Whether the air conditioner heats well in the case of the HEATING/COOLING type.

Caution: A protection feature prevents the air conditioner from being activated for approximately 3 minutes when it is restarted immediately after shut off.